

# Orion™

## WEATHER STATIONS

*Ultrasonic Wind | Temperature | Relative Humidity | Rainfall | Barometric Pressure*

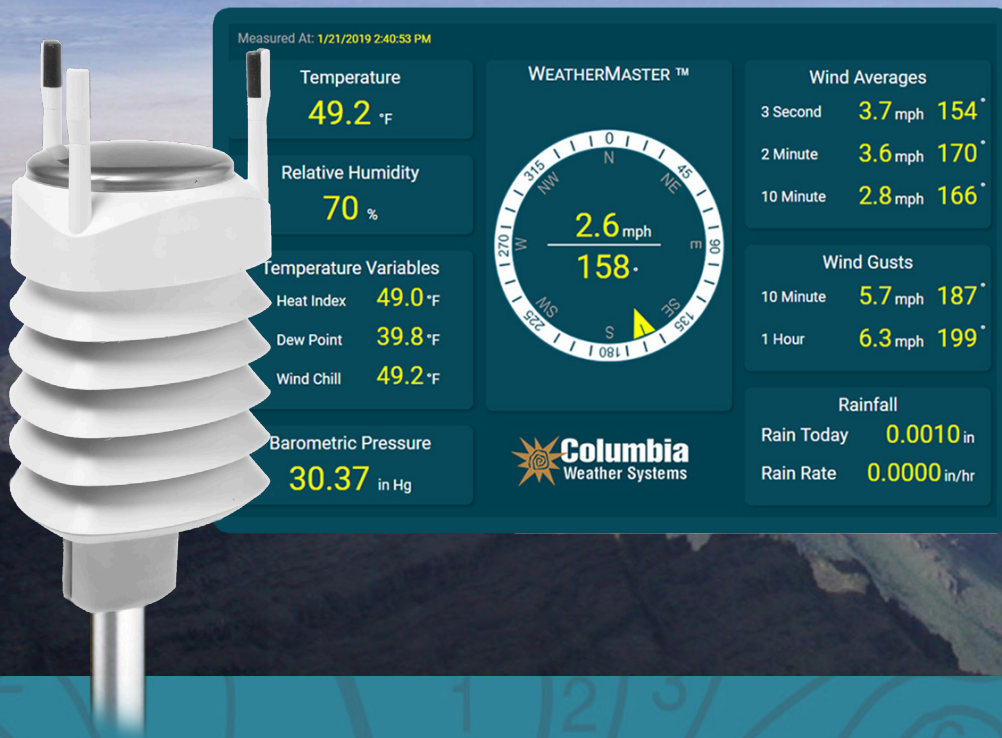

## Professional All-in-One Weather Monitoring

### Sensor Models



The Orion Weather Station™ includes a high-tech, all-in-one sensor module with ultrasonic wind direction and speed measurements, impact rain sensor, capacitive relative humidity, temperature and barometric pressure readings. High accuracy and fine resolution make this system ideal for precision weather monitoring.

Available in three configurations—fixed-mount, vehicle-mount, and the Orion Nomad™ portable weather station—Orion data can be monitored with our proprietary Weather Display Console™, WeatherMaster™ Software, and/or the Weather MicroServer™ for Internet-ready output as well as industrial automation interfaces including Modbus TCP/IP.

### Orion Weather Stations Feature

- Most essential weather parameters measured in one instrument
- Accurate and stable measurement
- Ultrasonic wind sensor and impact precipitation sensor
- No moving parts means virtually no maintenance
- Low power consumption improves reliability and longevity
- Compact and lightweight with a single cable for quick and easy installation

### All-in-One Sensor Modules

**Model 536:** Impact Rain Sensor, Ultrasonic Wind Speed and Direction, Temperature, Relative Humidity, Air Pressure

**Model 531:** Impact Rain Sensor

**Model 532:** Ultrasonic Wind Speed and Direction

**Model 533:** Impact Rain Sensor, Ultrasonic Wind Speed and Direction

**Model 534:** Air pressure, Temperature, Relative Humidity

**Model 535:** Impact Rain Sensor, Pressure, Temperature, Relative Humidity

### System Diagram

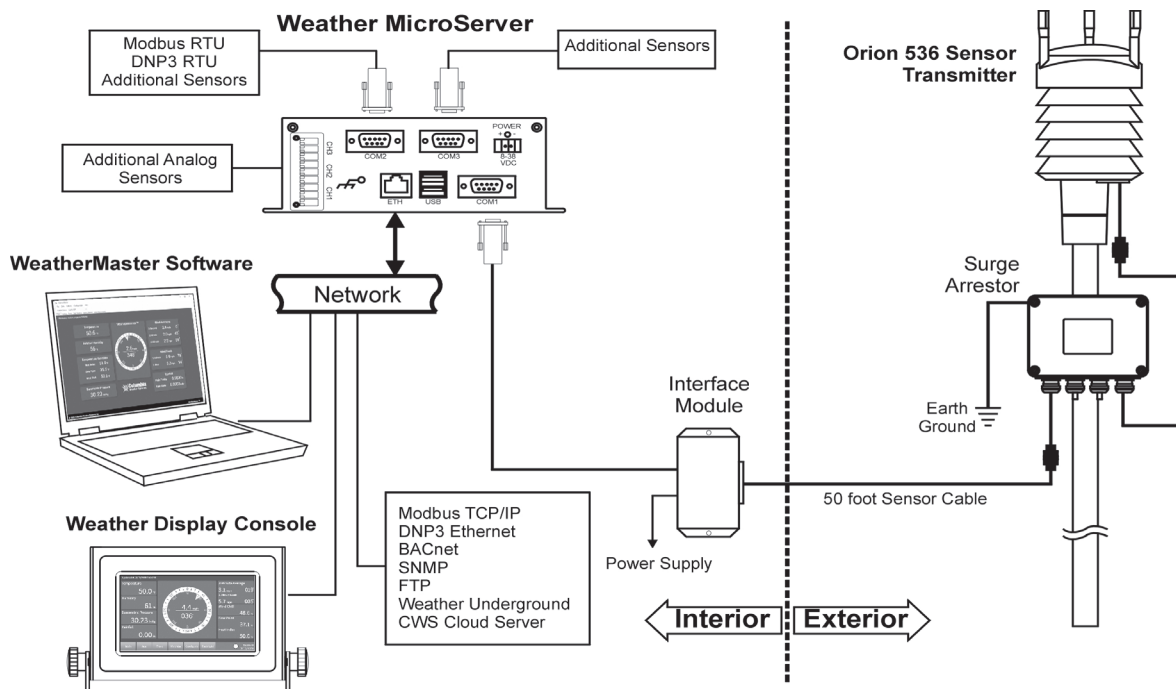

# Monitoring Options

## Weather MicroServer™

A self-contained, proprietary weather computer utilizing an embedded Linux operating system.

- "Internet-ready" weather monitoring with FTP output, XML, and Internet browser user interface
- Industrial communication protocols (SNMP, Modbus, DNP3, BACnet)
- Datalogging capability

Two serial ports offer interface to the Weather Display Console and additional sensors such as visibility and ultrasonic wind sensors.

The Weather MicroServer can provide real-time weather data to WeatherMaster Software and Display Console over the network.

This allows users to simultaneously monitor the weather using WeatherMaster on any network computer.



## Cloud Weather Server™

Free with the Weather MicroServer, this service offers real-time weather data monitoring on the Internet.

- View display screen remotely from any device using a web browser
- Data uploaded every five seconds
- For one or more weather stations

All monitoring devices can be factory-customized to suit application-specific requirements.

## CWS Weather Monitor App™



Check current conditions quickly from a hand-held mobile device for decision-making in the field. The CWS Weather Monitor App is compatible with all CWS weather stations that include the Weather MicroServer.

The app includes three real-time monitoring screens which display standard meteorological parameters. Access to a Cloud Weather Server account is required.



## Color Weather Display Console™

"Intelligent" touch-screen technology incorporates programmable microprocessor and abundant memory to display weather information, perform complex computations, and store data.

- Seven-inch, TFT color LCD panel with 800 x 480 pixels resolution
- Connect directly to the weather station with a serial port or to the Weather MicroServer utilizing existing Ethernet
- Three mounting options: Desktop/Wall-Mount, Panel Mount/Flush Mount, 19" Rack Mount

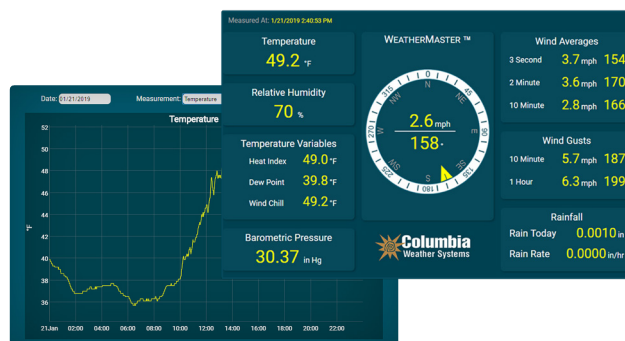

## WeatherMaster™ Software

Professional-grade software providing real-time computer weather monitoring with display and automatic logging of all measured and calculated parameters.

- Expandable SQL database to archive measured and calculated parameters
- Graphing and trend display of all parameters
- Alarm notification via computer, email, and/or text
- Multi-station monitoring and data acquisition
- Interface with CAMEO/ALOHA software for plume modeling and evacuation corridor predictions
- Interface with Weather Underground

## 4-20 mA Signal Output

For industrial PLC interface, the Orion 420™ offers 4-20mA signal output to interface to PLC, DCS, and SCADA systems.

# Specifications

## Temperature

Range: -60 to 140°F (-52 to +60°C)  
Accuracy: ±0.5°F (±0.3°C) at 68°F (+20°C)  
Resolution: 0.1°F (0.1°C)  
Units Available: °F, °C

## Barometric Pressure

Range: 17.50 to 32.50 InHg (600 to 1100 mbar)  
Accuracy: ±0.015 InHg (0.5 mbar) at +32 - 86°F (0-30°C)  
Resolution: 0.01 InHg (0.1 mbar)  
Units Available: KPa, mbar, InHg, HPa

## Wind Speed

Range: 0 - 135 mph (0 - 60 m/s)  
Accuracy: ±3% at 10 m/s  
Resolution: 1 mph (1 m/s)  
Units Available: knots, mph, km/hr, m/s

## Wind Direction

Azimuth: 0 - 360°  
Accuracy: ±3°  
Resolution: 1°

## Relative Humidity

Range: 0 - 100%RH  
Accuracy: ±3%RH (0-90%), ±5% (90-100%)  
Resolution: 1%RH  
Units Available: %RH

## Rainfall

Range: cumulative  
Collection Area: 60 cm<sup>2</sup>  
Accuracy: ±5% (spatial variations may exist)  
Resolution 0.001 in. (0.0254mmw )  
Units Available: mm, inches

## Parameter Measurements

**Barometric pressure, temperature, and humidity** are combined in a tri-sensor module utilizing a capacitive measurement method for each parameter. The internal sensor module is easily replaceable and available as a spare part.

A radiation shield protects the sensors from sunlight and precipitation. The composite material offers excellent thermal characteristics and UV stabilized construction. The white outer surface reflects radiation, while the black inside absorbs accumulated heat.

**Barometric pressure** is measured using a silicon-based sensor. The temperature sensor is ceramic. Relative humidity measurement is highly accurate with negligible hysteresis and excellent long-term stability.

**Wind speed and direction** are measured with three equally-spaced ultrasonic transducers on a horizontal plane, ensuring accurate wind measurement from all directions.

**Rainfall** is measured with an impact sensor which detects the size and impact of individual rain drops. Resulting signals are proportional to the volume of the drops, thus converting directly to accumulated rainfall. This method eliminates scattering, flooding and clogging, as well as wetting and evaporation losses.

**Additional calculated parameters:** Data from these sensors are computed to provide calculated parameters including Dew Point, Heat Index, Wind Chill, Degree-Day Temperatures and Density Altitude.

## System Configurations

All Orion weather station systems include:

- Orion Transmitter/Sensor Module (select model)
- Interface Module with dual communication ports
- Select the desired monitoring option(s) from the previous page
- One-year warranty, extended warranty available

**Fixed-Base Weather Stations** include 50-ft cable. Optional sensor mast, mounting hardware, and extra-cable length are available.

**Vehicle-Mount Weather Stations** include a detachable 9-ft telescoping sensor mast and mounting hardware.

**Orion Nomad Portable Weather Stations** include wireless transceivers, batteries, transportation case and tripod with 10-ft telescoping mast.

**Contact us today for a free quotation!**

## Orion Transmitter/Sensor Module

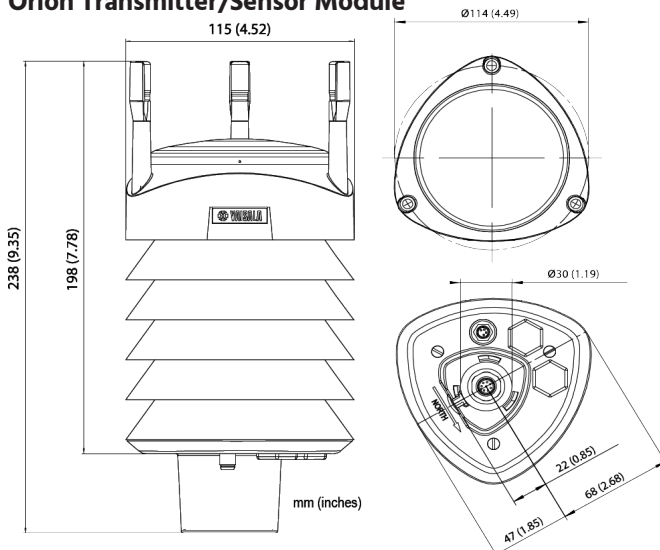

5285 NE Elam Young Pkwy, Suite C100, Hillsboro, OR 97124 | phone 503-629-0887  
info@columbiaweather.com | fax 503-629-0898 | ColumbiaWeather.com

©2020 Columbia Weather Systems, all rights reserved. Specifications may change without notice.