

# Diagnostic testing and monitoring of power transformers

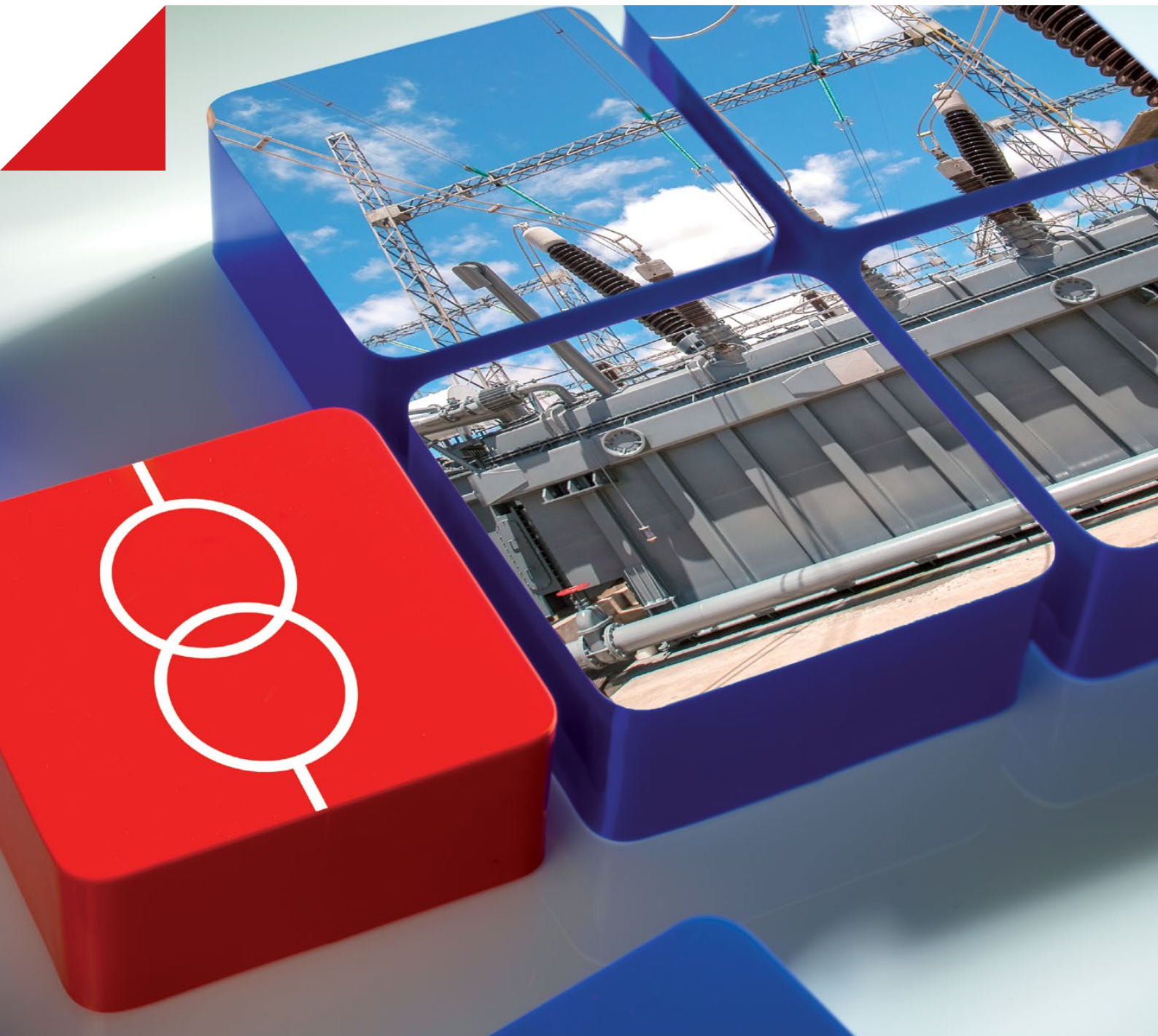

# Know the condition of your transformer to get the most out of your

During commissioning and operation it is essential that your power transformer is in good condition. Various influences can impact the expected lifetime throughout a transformer's lifecycle.

Diagnostic testing and monitoring will help you to determine your asset's condition and choose the right corrective measures to ensure reliable operation and extend the transformer's life expectancy.

## Negative influences on a transformer's life expectancy

- › **Thermal influences**  
Overload, overheating, ambient conditions
- › **Aging**  
Moisture, acids, oxygen, contamination, leakages
- › **Mechanical influences**  
Transportation damage, short-circuit stresses, seismic activity
- › **Electrical influences**  
Switching surges, lightning, overvoltages, short-circuit currents
- › **Protection problems**  
Underfunction, failure



Manufacturing

Commissioning

asset

### Testing and corrective measures to extend a transformer's life expectancy

- > **Maintain auxiliary components**  
Tap changers, cooling system, breather
- > **Recondition of insulation**  
Drying, oil treatment, oil change
- > **Replace parts**  
Bushings, surge arresters, gaskets, pumps and fans

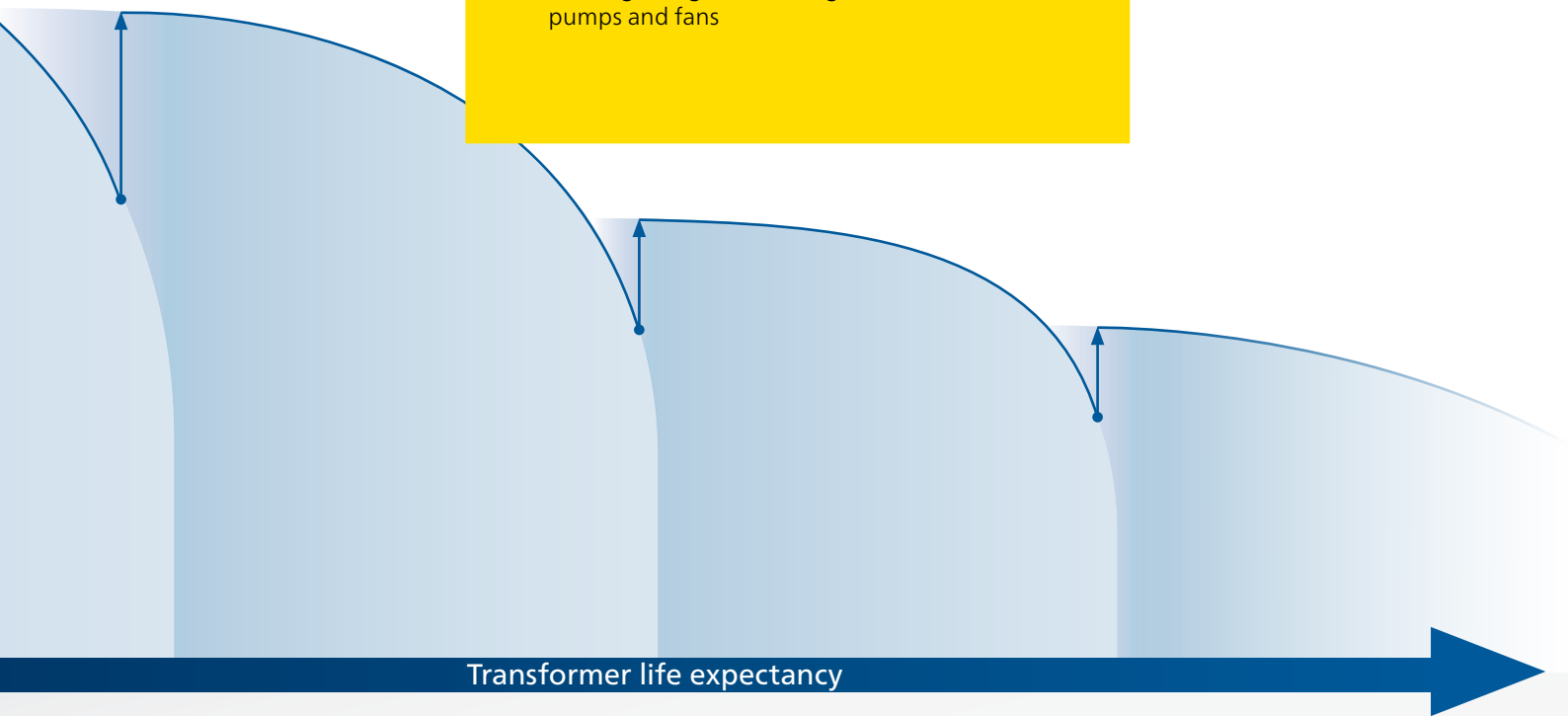

Operation

# Transformer components and their detectable faults

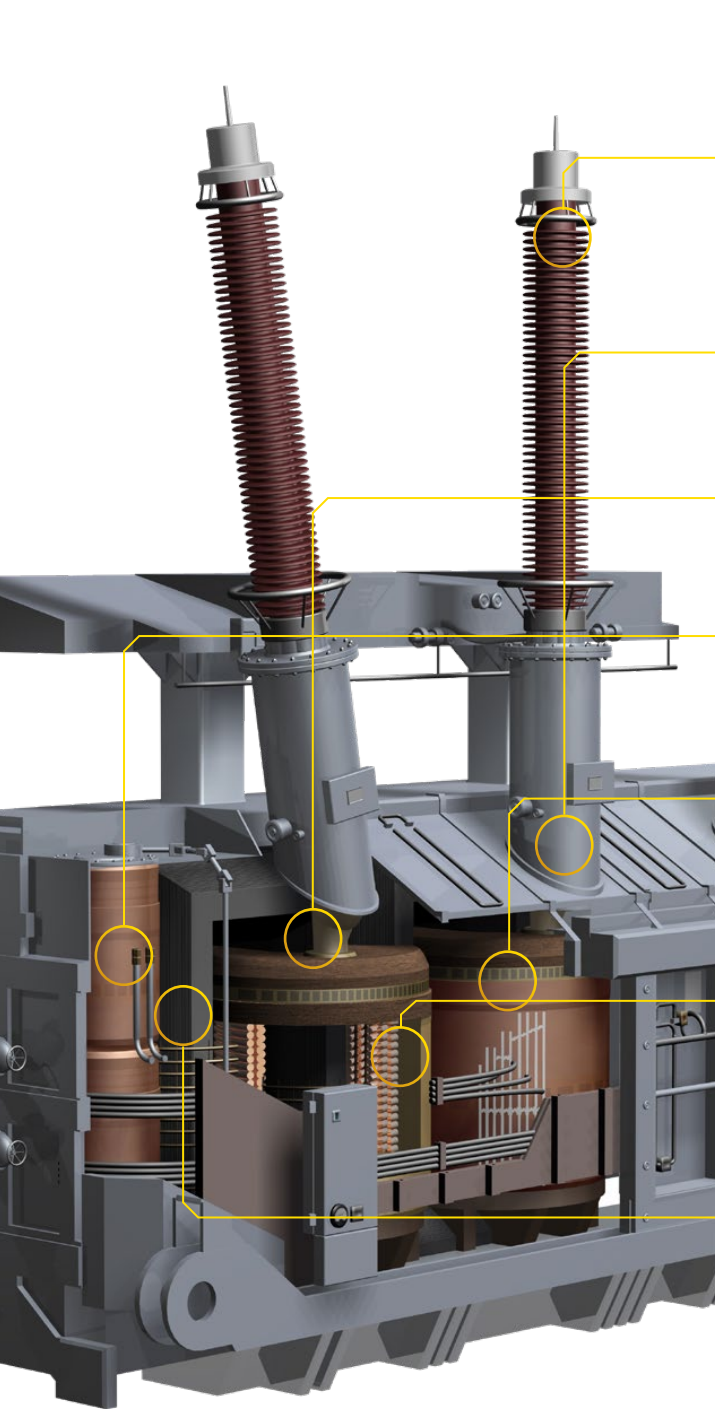

Component	Detectable faults
Bushings	<ul style="list-style-type: none"> <li>Partial breakdown between capacitive graded layers, cracks in resin-bonded insulation</li> <li>Aging and moisture ingress</li> <li>Open or compromised measuring tap connection</li> <li>Partial discharges in insulation</li> </ul>
CTs	<ul style="list-style-type: none"> <li>Current ratio or phase error considering burden, excessive residual magnetism, non-compliance to relevant IEEE or IEC standard</li> <li>Burden-dependent current ratio and phase displacement</li> <li>Shorted turns</li> </ul>
Leads	<ul style="list-style-type: none"> <li>Contact problems</li> <li>Mechanical deformation</li> </ul>
Tap changer	<ul style="list-style-type: none"> <li>Contact problems in tap selector and at diverter switch</li> <li>Open circuit, shorted turns, or high resistance connections in the OLTC preventative autotransformer</li> <li>Contact problems in the DETC</li> </ul>
Insulation	<ul style="list-style-type: none"> <li>Moisture in solid insulation</li> <li>Aging, moisture, contamination of insulation fluids</li> <li>Partial discharges</li> </ul>
Windings	<ul style="list-style-type: none"> <li>Short-circuits between windings or between turns</li> <li>Strand-to-strand short-circuits</li> <li>Open circuits in parallel strands</li> <li>Short-circuit to ground</li> <li>Mechanical deformation</li> <li>Contact problems, open circuits</li> </ul>
Core	<ul style="list-style-type: none"> <li>Mechanical deformation</li> <li>Floating core ground</li> <li>Shorted core laminates</li> <li>Residual magnetism</li> </ul>



# The ideal solution for your individual needs and requirements/applic

	TESTRANO 600	CPC 100	CPC 80 + CP TD12/15	TANDO 700
<b>Capacitance and power factor/dissipation factor measurement:</b>				
at 50 Hz or 60 Hz	■ <sup>1</sup>	■ <sup>1</sup>	■	■ <sup>4</sup>
as tip-up test	■ <sup>1</sup>	■ <sup>1</sup>	■	■ <sup>4</sup>
with variable frequency	■ <sup>1</sup>	■ <sup>1</sup>	■	■ <sup>4</sup>
<b>DC winding resistance measurement and OLTC verification</b>	■	■ <sup>2</sup>		
<b>Transformer turns ratio (TTR) measurement</b>	■	■ <sup>3</sup>		
<b>Exciting current measurement</b>	■	■ <sup>1</sup>		
<b>Short-circuit impedance / leakage reactance measurement</b>	■	■		
<b>Frequency response of stray losses (FRSL) measurement</b>	■	■		
<b>Demagnetization</b>	■	■ <sup>2</sup>		
<b>Dielectric (frequency) response analysis</b>				
Sweep frequency response analysis (SFRA)				
Current transformer analysis			■	
Partial discharge analysis				
Partial discharge localization				
On-line partial discharge measurement & temporary monitoring				

<sup>1</sup> Additional accessory CP TD12/15 required  
<sup>2</sup> Additional accessory CP SB1 required  
<sup>3</sup> Optional accessory CP SB1 available to speed up testing  
<sup>4</sup> Additional power supply and standard capacitor required

Three-phase test set for the fastest and most comprehensive diagnostic testing and condition assessment of power transformers.



Multi-functional test set for a comprehensive condition diagnosis and condition assessment of multiple high-voltage assets.



Power/dissipation factor and capacitance test set, (including source and reference capacitor) for various high-voltage assets.



Ultra-precise test set for dissipation/power factor and capacitance measurements on high-voltage assets (with an external source and reference capacitor)



ation

DIRANA

FRANEO 800

CT ANALYZER

MPD 800

PDL 650

MONTESTO 200

■

■

■

■

■

■

■

Lightweight test set for fast and reliable moisture content determination of oil-paper insulated power transformers.

Smart test set for sweep frequency response analysis (SFRA) on power transformer core and windings.

Highly accurate and lightweight test set for current transformer calibration and verification.

Universal partial discharge (PD) measurement and analysis system

Test set for convenient partial discharge localization in power transformers.

Portable on-line partial discharge measurement and temporary monitoring system.



# Capacitance and power factor/dissipation factor measurement

## What can be tested?

- ✓ Bushings
- CTs
- Leads
- Tap changer
- ✓ Insulation
- Windings
- Core

## Why measure?

Capacitance and power factor/dissipation factor (PF/DF) measurements are performed to investigate the condition of the insulation of power transformers and bushings. Both insulation systems are essential for the reliable operation of the transformer.

High oil conductivity, aging and an increase in the water content are symptoms of the degradation process in the insulation. These symptoms also result in an increase of losses, which can be quantified by measuring the power factor or dissipation factor.

Changes in capacitance can indicate partial breakdown between the capacitive layers of bushings. By measuring the capacitance and losses, problems in the insulation can be detected before a failure occurs.

One of the major causes for transformer outages is the replacement of bushings due to a deterioration or failure of the insulation.

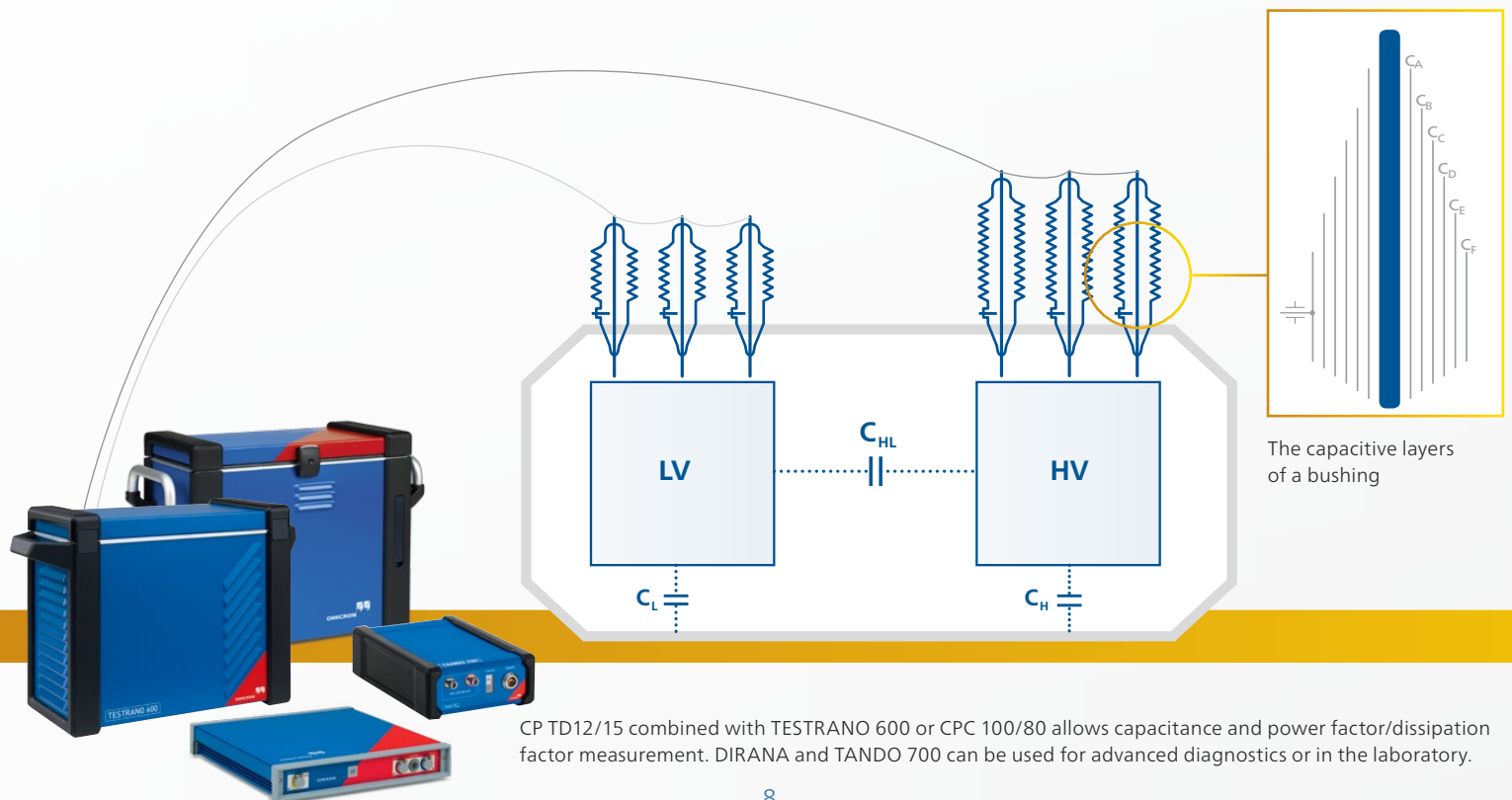



## How does it work?

On power transformers, measurements are performed on the main insulation between the windings ( $C_{HL}$ ) and the insulation from the windings to the tank ( $C_{HT}$ ,  $C_{LT}$ ). The windings are shorted and the test voltage is applied to one winding while the current through the insulation is measured on the opposite winding or the tank.

On bushings, the voltage is applied to the main conductor while measuring the current on the measurement tap.

The dissipation factor, also called  $\tan(\delta)$ , is calculated via the tangent of the angle  $\delta$  between the measured current and the ideal current which would occur if no losses would exist. The power factor is the cosine of the angle  $\phi$ , therefore also called  $\cos(\phi)$ , between the output voltage and the measured current.

Using frequencies other than line frequency increases the sensitivity of the measurement as some problems are more dominant at frequencies above or below line frequency. Modern test devices can perform automatic frequency or voltage sweeps.

The dielectric losses cause a phase shift

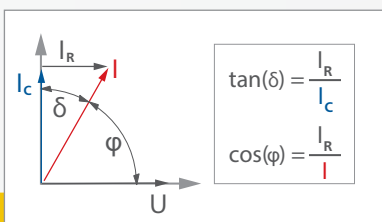
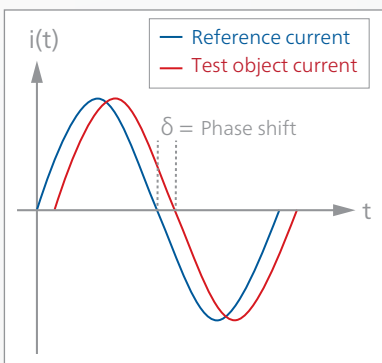

The  $\tan(\delta)$  of four different transformers below and above line frequency (50 Hz).

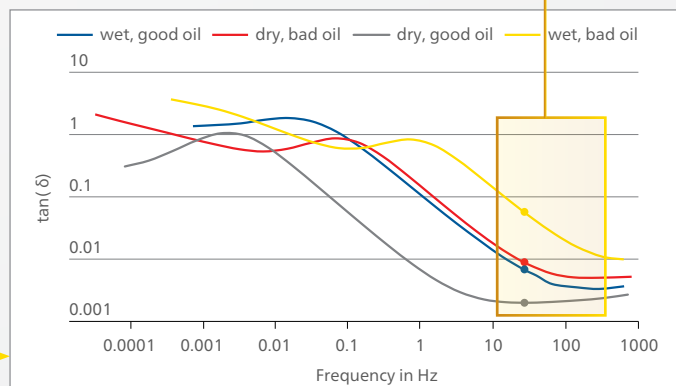
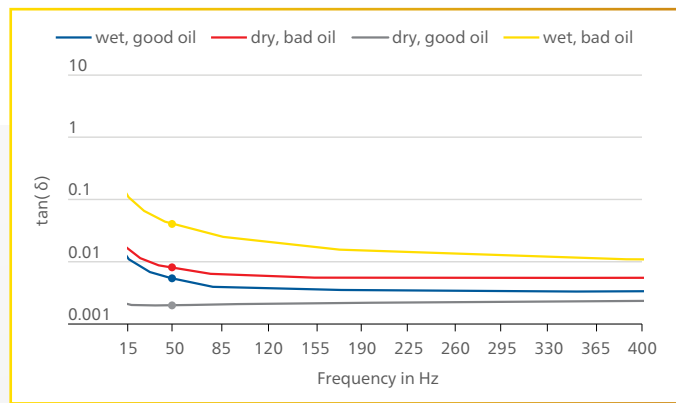

Depending on the test device, different frequency ranges can be measured, e.g. from 15 Hz to 400 Hz with TESTRANO 600 and from 10  $\mu$ Hz to 5 kHz with DIRANA.

# Capacitance and power factor/dissipation factor measurement

## Good to know ...

After the measurements have been completed, it is beneficial to compare the values to previous results and reference values mentioned in the relevant standards for the tested asset.

A rise in capacitance of more than 10 % compared to previous results is normally considered to be dangerous for bushings. It indicates that a part of the insulation distance is already compromised and the dielectric stress to the remaining insulation is too high.

An additional voltage tip-up test can detect bad contacts of the bushing layers or the measurement tap. They can be recognized by a decreasing PF/DF.

Standard PF/DF measurements at 50 Hz or 60 Hz can only detect the effects of moisture and aging at an advanced stage. By performing the measurement across a wider frequency range, these effects can be detected at an earlier stage allowing for a longer reaction time to schedule corrective action.

If a high PF/DF is detected, dielectric response analysis can be used as a supplementary diagnostic method. This broadband dielectric measurement can be used to determine whether the high PF/DF is caused by moisture or a high oil conductivity.

Insulating liquid	kV rating	Nominal/new PF/DF limit	Serviceability aged limit
Mineral oil	< 230 kV	0.5 %	1.0 %
Mineral oil	≥ 230 kV	0.5 %	1.0 %
Natural oil	All	1.0 %	1.0 %

Typical values for power factor/dissipation factor of transformers, depending on the used insulating liquid at 20°C/68°F according to international standards (IEEE C.57-152)

Insulation type	New bushings	IEEE C57.19.01	IEC 60137
Resin impregnated paper (RIP)	0.3 % ... 0.4 %	< 0.85 %	< 0.70 %
Oil impregnated paper (OIP)	0.2 % ... 0.4 %	< 0.50 %	< 0.70 %
Resin bonded paper (RBP)	0.5 % ... 0.6 %	< 2.00 %	< 1.50 %

Typical values for power factor/dissipation factor of bushings at line frequency and at 20°C/68°F according to international standards

## Our solutions ...

We offer a wide range of solutions for capacitance and power factor/dissipation factor ( $\tan \delta$ ) measurements. They range from mobile solutions for comfortable on-site testing, through high precise solutions for laboratory use, up to dedicated test sets for advanced power transformer condition diagnosis, such as moisture determination.

	Measurement range	Typical application
<b>TESTRANO 600 + CP TD12/15</b>	0 ... 12 kV/15 kV 15 Hz ... 400 Hz	Dedicated condition diagnosis of power transformers on-site and during manufacturing
<b>CPC 100 + CP TD12/15</b>	0 ... 12 kV/16 kV 15 Hz ... 400 Hz	General condition diagnosis of multiple assets on-site and during manufacturing
<b>CPC 80 + CP TD12/15</b>	0 ... 12 kV / 15 kV 15 Hz ... 400 Hz	Dedicated power factor/dissipation factor testing of multiple assets on-site and during manufacturing
<b>TANDO 700</b>	Voltage depending on external source 5 Hz ... 400 Hz	High-voltage laboratory tests, e.g. for routine and type tests or material tests of multiple assets
<b>DIRANA</b>	max. 200 V <sub>peak</sub> 50 $\mu$ Hz ... 5 kHz	Advanced condition diagnosis and moisture determination in oil-paper insulation

# DC winding resistance measurement and OLTC verification

## What can be tested?

- Bushings
- CTs
- ✓ Leads
- ✓ Tap changer
- Insulation
- ✓ Windings
- Core

## Why measure?

Winding resistance measurements are performed for assessing possible damage in windings or contact problems, such as from the bushings to the windings, the windings to the tap changer, etc.

They are also used to check the on-load tap changer (OLTC) as they can indicate when to clean or replace OLTC contacts, or when to replace or refurbish the OLTC itself. Failures can be detected without opening the tap changer compartment.

## How does it work?

To measure the winding resistance, the winding must be charged until the core is saturated. The resistance can then be determined by measuring DC current and DC voltage. For tapped windings, this should be done for every tap position, hence testing the OLTC and the winding together. There are two common approaches for this test: static and dynamic winding resistance measurements.

**Static winding resistance measurements** are the most common and easiest way to check for issues regarding the winding and OLTC. It investigates the resistance of each subsequent tap position and compares it with the reference measurement data of the manufacturer.

**Dynamic resistance measurements** are performed as a supplementary measurement in order to analyze the transient switching process of a resistive diverter OLTC. It investigates the switching process of the diverter switch itself. When switching the tap changer during winding resistance measurements, the DC current temporarily decreases and this behaviour is recorded and analyzed.

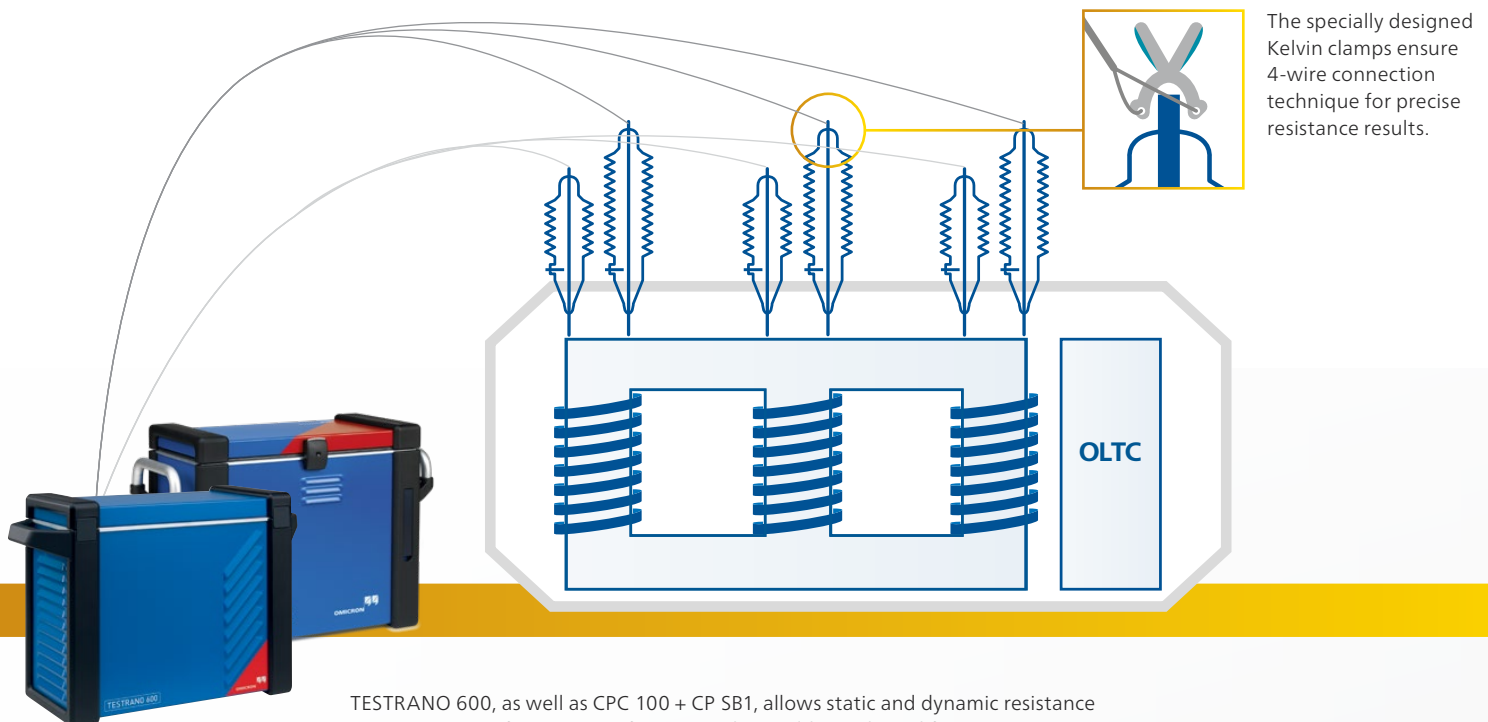

TESTRANO 600, as well as CPC 100 + CP SB1, allows static and dynamic resistance measurements of power transformers with no additional need for rewiring.

## Good to know ...

For DC winding resistance, the results should not differ more than 1 % compared to the reference measurement. In addition, differences between phases are usually less than 2-3 %.

When comparing winding resistance measurements, the results have to be temperature corrected. The usual reference temperature is 75 °C / 167 °F.

A transformer turns ratio measurement can be used to confirm an open circuit while a frequency response analysis can be used to confirm contact problems.

In both cases an additional gas analysis can indicate hot spots in the transformer. However, gas signatures are not unique and, thus, do not allow for the identification of the root cause.

During DC winding resistance measurements the core of the transformer may be magnetized. Therefore, it is recommended to demagnetize the core after performing this test.

## Why use TESTRANO 600?

- > Three-phase measurement of HV and LV windings without reconnection using up to 33 A DC
- > Single-phase measurement of low ohmic windings using up to 100 A DC
- > Automatic tap changer control and measurement of OLTC motor current and voltage
- > Demagnetize the core and measure turns ratio without changing any leads

## Why use CPC 100 + CP SB1?

- > Measurement of all three phases without reconnection using CP SB1 with up to 6 A DC
- > Single-phase measurement of low ohmic windings with up to 100 A DC
- > Automatic tap changer control using CP SB1

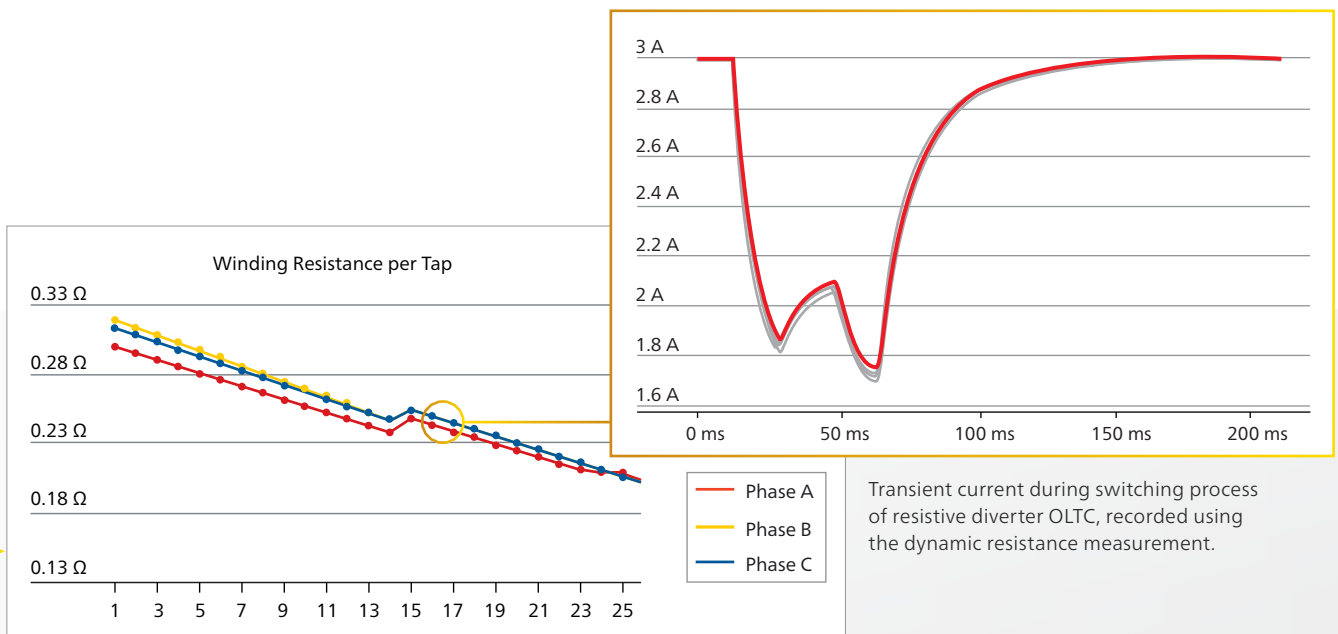

Winding resistance per tap, recorded using the static winding resistance measurement.

Transient current during switching process of resistive diverter OLTC, recorded using the dynamic resistance measurement.

# Transformer turns ratio (TTR) measurement

## What can be tested?

- Bushings
- CTs
- Leads
- Tap changer
- Insulation
- ✓ Windings
- Core

## Why measure?

Transformer turns ratio (TTR) measurements are performed to verify the fundamental operating principle of a power transformer. By measuring the ratio and phase angle from one winding to the other, open circuits and shorted turns can be detected.

The turns ratio is determined during factory acceptance tests (FAT) and needs to be checked routinely once the transformer is in service. TTR measurements can also be triggered by a tripped relay and other diagnostic tests like dissolved gas analysis (DGA) and dissipation factor/power factor measurements.

## How does it work?

When using a **single-phase source**, the test voltage is applied to each phase of one winding and measured on both the high-voltage and corresponding low-voltage winding of the same leg.

By using a **three-phase source**, the same measurement can be performed on all three phases at the same time.

The calculated ratio can then be compared to the factory results which are available on the nameplate.

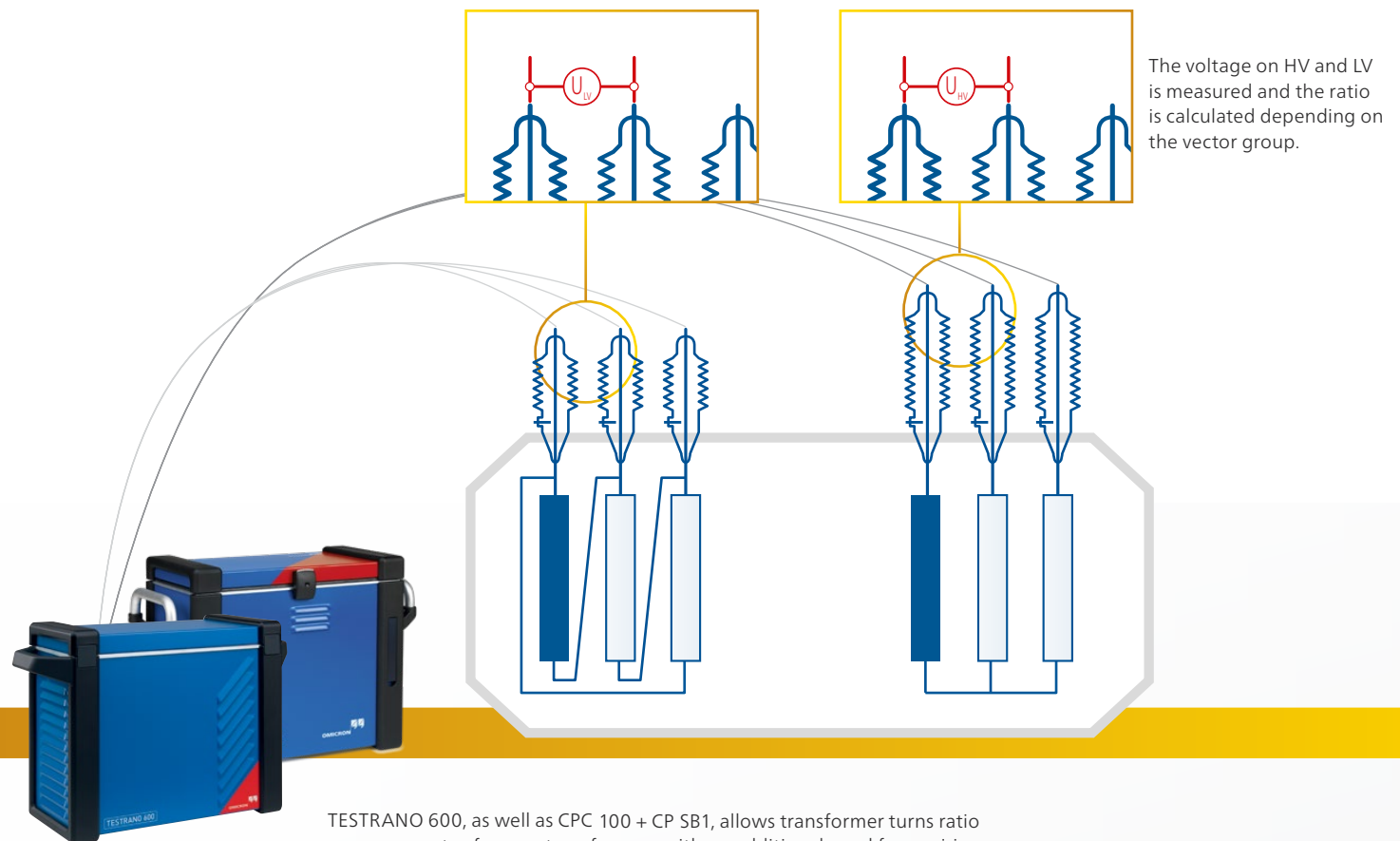

TESTRANO 600, as well as CPC 100 + CP SB1, allows transformer turns ratio measurements of power transformers with no additional need for rewiring.

## Good to know ...

Results are compared with nameplate values and across phases. According to IEC 60076-1 and IEEE C57.152 the measured values should not deviate more than 0.5 % from the nominal ratio.

The turns ratio is usually measured from the high-voltage to the low-voltage winding, in order to avoid unsafe voltage on the measurement inputs.

A magnetized core or missing ground reference may influence the measurement and lead to incorrect results. Making sure the transformer core is demagnetized and proper grounds are established on each winding is therefore very important.

To confirm or eliminate a suspected problem, an additional exciting current test is useful to diagnose short-circuited conditions, while DC winding resistance tests are very sensitive to open-circuited conditions.

## Why use TESTRANO 600?

- > True three-phase measurement to determine the ratio and phase displacement of any winding configuration
- > Measurements up to 400 V AC (L-L) without reconnection
- > Same wiring used to test DC winding resistance, no lead change required
- > Automatic tap changer control built into the unit, no accessory required

## Why use CPC 100 + CP SB1?

- > Measurement of all three phases without reconnection with up to 300 V AC (L-L) using CP SB1
- > Perform single-phase measurements with up to 2 kV AC
- > Automatic tap changer control using CP SB1

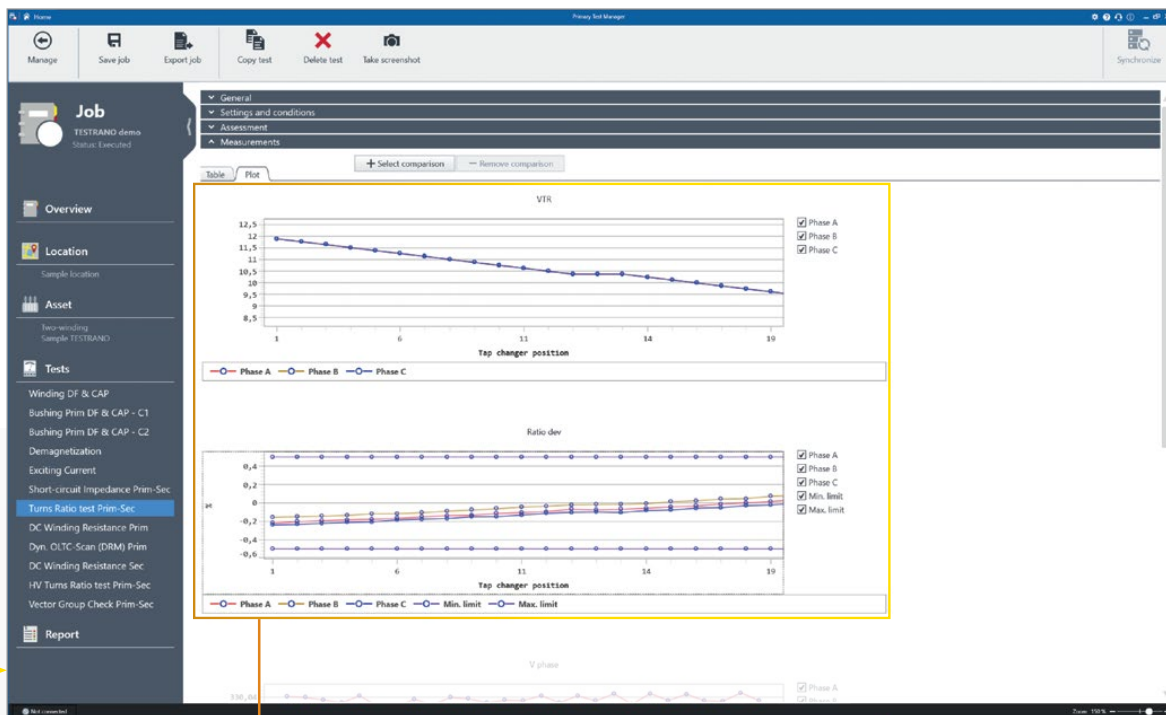

The TTR is measured for all three phases at each tap position. According to international standards the results should not deviate more than 0,5 % from the nominal nameplate values.

# Exciting current measurement

## What can be tested?

- Bushings
- CTs
- Leads
- Tap changer
- Insulation
- ✓ Windings
- ✓ Core

## Why measure?

Exciting current measurements are performed to assess the turn-to-turn insulation of the windings, the magnetic circuit of a transformer as well as the tap changer.

The most valued benefit of the test is to detect turn-to-turn short-circuits in a winding. Physical movement of the core laminations severe damage of the core can influence the reluctance and, thus, will result in a change in exciting current. Deviations may also indicate contact wear or improper wiring of the tap changer.

## How does it work?

The exciting current test is measured under no-load conditions. Therefore, an AC voltage is applied to one side of the transformer (usually the high-voltage side) while the opposite side is left open. The magnitude of the current drawn in the primary winding is proportional to the energy required to force the transformer action, i.e. induce a voltage in the secondary winding.

It is recommended to select the highest test voltage within the limitations of the test set and the winding, in order to detect turn-to-turn short-circuit faults. A standard test voltage is 10 kV.

The test connections will vary depending on the winding configuration. In general, neutral bushings on the energized winding, if present, should be connected to the low-voltage return lead. Neutral bushings on the open winding should be grounded, if also grounded in service.

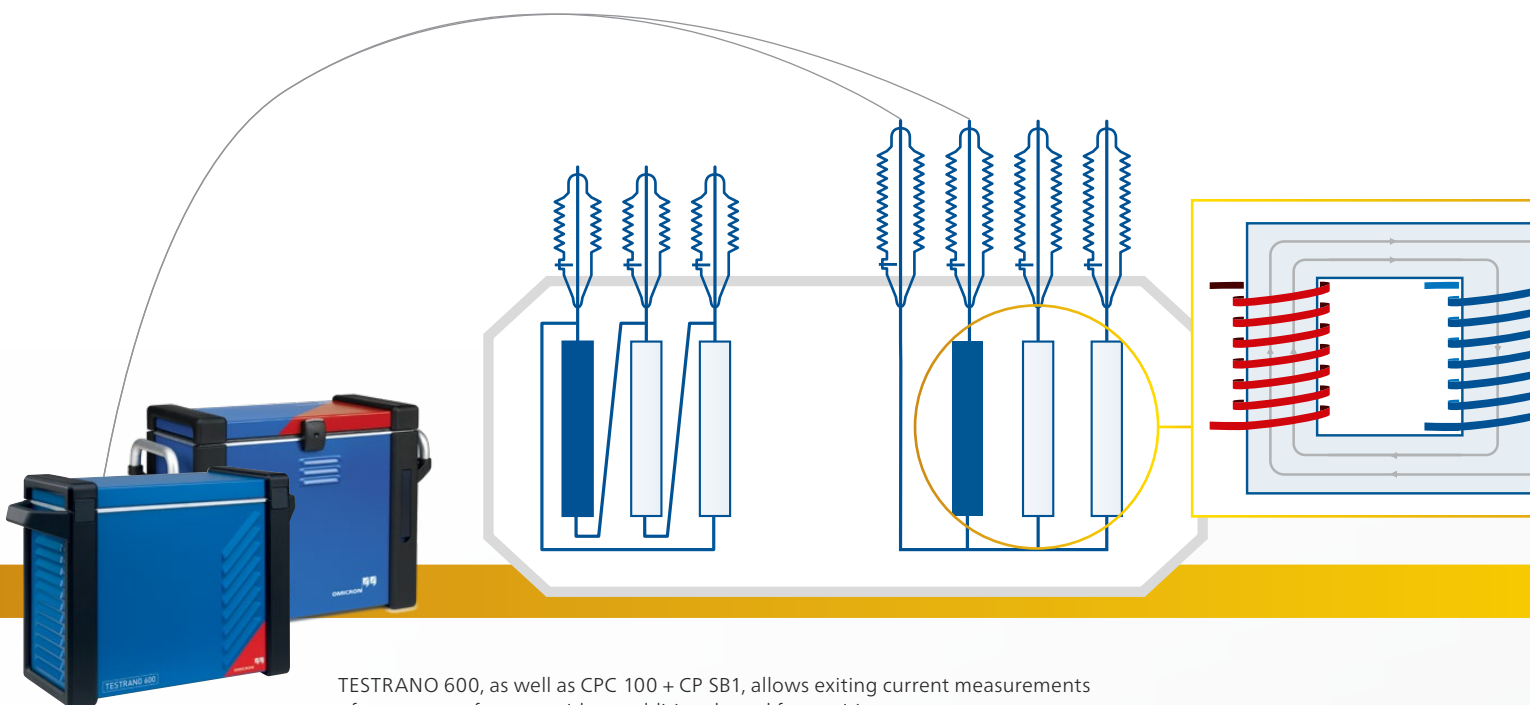

TESTRANO 600, as well as CPC 100 + CP SB1, allows exciting current measurements of power transformers with no additional need for rewiring.



## Good to know ...

Exciting current test should be compared among phases and tap positions. Depending on the construction of the transformer and number of legs, the results should show a distinct phase pattern with either two or three similar phases (HLH, LHL, HHH). The similar phases should not deviate more the 5 % to 10 % from each other.

If all three phases show different exciting currents, further investigation is recommended. The dissimilar phase pattern could be caused by a magnetized core or a winding problem.

As mentioned above, residual magnetism in the core can influence the results. In this case the transformer should be demagnetized and the test repeated.

In addition to the phase pattern, results should also show a distinctive pattern across all tap positions which may vary depending on the type of tap changer. Even if the specific tap changer pattern is not known, it should be the same for all phases.

Short-circuited turns can also be confirmed by transformer turns ratio (TTR) measurements, while sweep frequency response analysis (SFRA) tests are helpful to confirm or further diagnose problems in the core.

## Why use TESTRANO 600 or CPC 100?

- > Perform exciting current tests at the usual test voltage of 10 kV, using CP TD12/15
- > Determine exciting currents while measuring turns ratio
- > Determine exciting currents of all three phases without reconnection

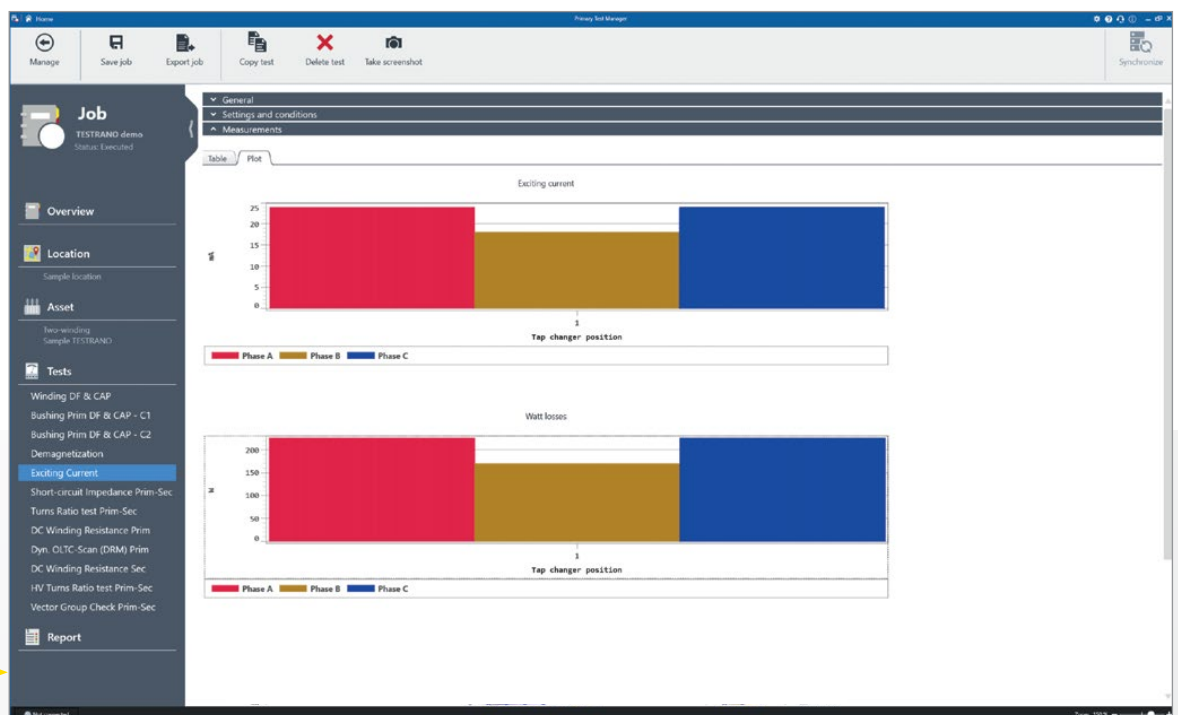
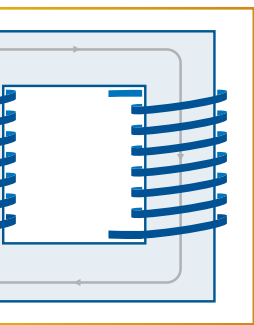

A typical HLH phase pattern of a three-legged transformer with two similar high values on the outer phases and one lower value on the center phase.

# Short-circuit impedance / leakage reactance measurement

## What can be tested?

- Bushings
- CTs
- Leads
- Tap changer
- Insulation
- ✓ Windings
- Core

## Why measure?

Short-circuit impedance / leakage reactance measurements are sensitive methods to assess possible deformation or displacement of windings.

Severe short-circuits or transportation of the power transformer may cause the windings to move or become deformed. In events like these, short-circuit impedance / leakage reactance tests are recommended.

The tests are usually performed as a three-phase measurement which can be compared to the nameplate value established by the manufacturer during factory acceptance tests. As this value represents the average across all three phases, a per-phase measurement is also recommended for winding diagnosis.

## How does it work?

An AC source is connected to each phase of the high-voltage winding. During the three-phase measurement, all three phases of the low-voltage side are shorted without connecting the neutral terminal, when present. For the per-phase test, the short-circuit is only applied on the corresponding winding on the low voltage side.

The current and the voltage across the high-voltage winding are measured in amplitude and phase. Finally, the short-circuit impedance is calculated by considering the specific transformer ratings.

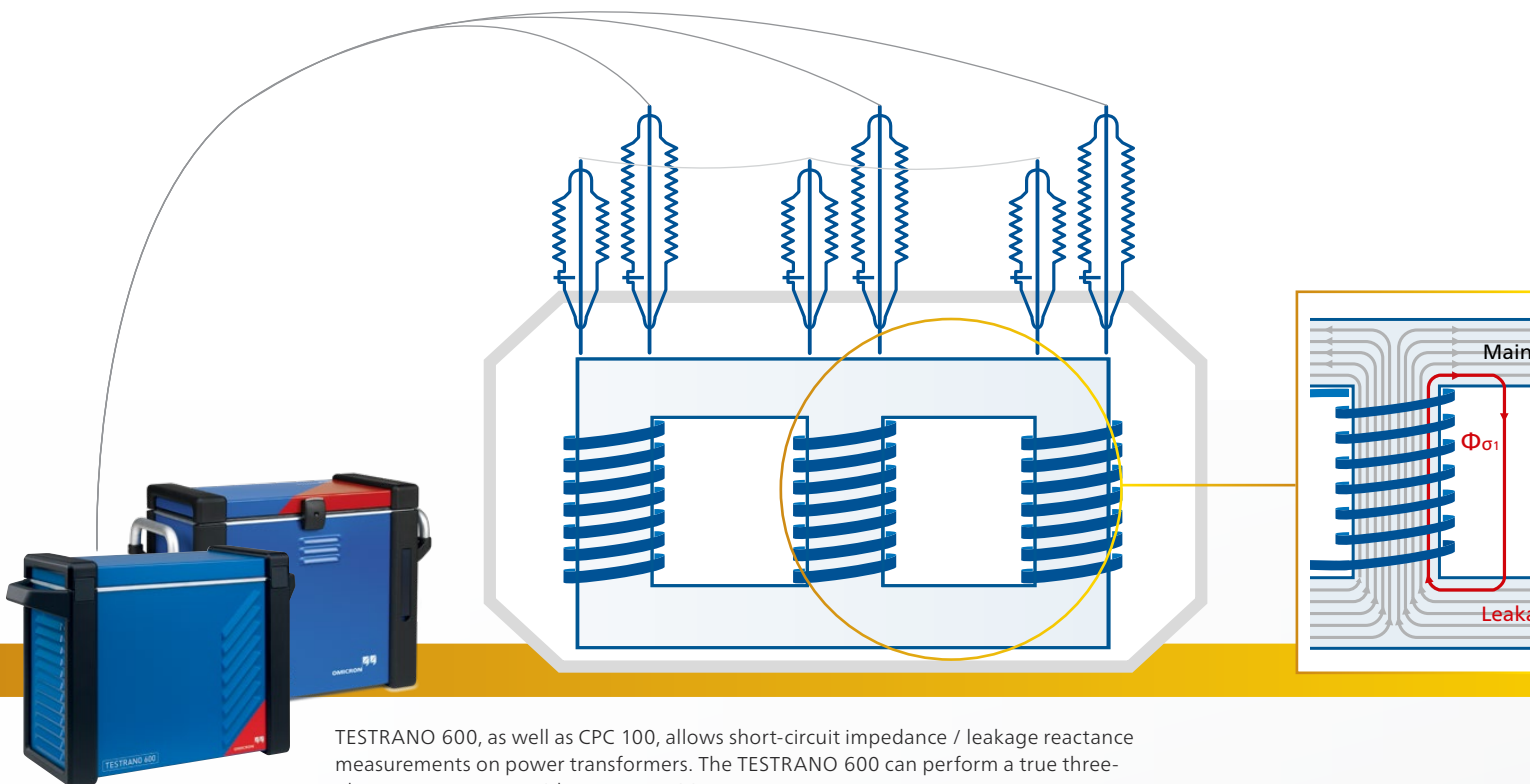

TESTRANO 600, as well as CPC 100, allows short-circuit impedance / leakage reactance measurements on power transformers. The TESTRANO 600 can perform a true three-phase measurement without any rewiring.

### Good to know ...

The short-circuit impedance obtained from the three-phase measurement should not deviate more than 3 % from the nameplate value.

However, higher deviations do not automatically confirm winding deformation. In order to do so, at least one of the per-phase leakage reactance test results must fail.

Each phase result should be compared to the average of all three measurements of the per-phase test. In most cases deviations from the average will be less than 1 % and should not exceed 2-3 %. The results of the per-phase test cannot be compared to the nameplate value.

The leakage reactance represents only the reactive part of the short-circuit impedance. However both terms are used synonymously to refer to the same test method.

In addition, a sweep frequency response analysis (SFRA) can be performed to further investigate winding movement and deformation.

### Why use TESTRANO 600?

- > True three-phase measurement to determine the short-circuit impedance without reconnection
- > Similar test method as used during factory acceptance tests
- > Same wiring used as for FRSL measurements

### Why use CPC 100?

- > Single-phase measurements to determine three-phase equivalent and per-phase short-circuit impedance
- > Same wiring used as for FRSL measurements

The leakage reactance represents the leakage flux, which is the flux not fully contained in the core. A shift or deformation of the windings will change the reluctance of the leakage path and, thus, the reactance.

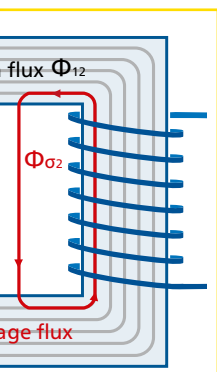

Short circuit impedance results (Zk)					
	Phase	I AC	V1 AC	V1 AC phase	Wat
Start	A	941,02 mA	164,73 V	87,09 °	7,87
Start	B	959,90 mA	168,62 V	87,08 °	8,24
Start	C	970,41 mA	168,56 V	86,97 °	8,64

Assessment uk		
Phase	uk meas (%)	uk ref (%)
	8,67 %	8,45 %

The short-circuit impedance is calculated based on the measured three-phase results and the power ratings of the transformer. Then, it is compared to the nominal value on the transformer nameplate.

# Frequency response of stray losses (FRSL) measurement

## What can be tested?

- Bushings
- CTs
- Leads
- Tap changer
- Insulation
- ✓ Windings
- Core

## Why measure?

The frequency response of stray losses (FRSL) test is a measurement of the resistive component of the short-circuit impedances at multiple frequencies. It is the only electrical method to identify short-circuits between parallel strands and local overheating due to excessive eddy current losses.

Similar to the short-circuit and leakage reactance test, it is recommended to perform the FRSL measurement as a commissioning or acceptance test to establish benchmark results. Likewise FRSL tests are not routine diagnostic tests, but are recommended for advanced diagnostics. The test can also be performed as a three-phase or per-phase test.

## How does it work?

The test setup and procedure of the FRSL test is the same as for short-circuit impedance/leakage reactance testing and can be performed simultaneously.

An AC source is connected to each phase of the high-voltage winding. During the three-phase measurement, all three phases of the low voltage side are shorted without connecting the neutral terminal, when present. For the per-phase test, the short-circuit is only applied on the corresponding winding of the low voltage side.

From the measured current, voltage and phase displacement the resistive component of the short-circuit impedance is calculated at discrete frequencies between 15 and 400 Hz.

As the eddy losses in the transformer become more pronounced at higher frequencies, a rise in the resistive component can be observed by plotting the results over the range of frequencies.

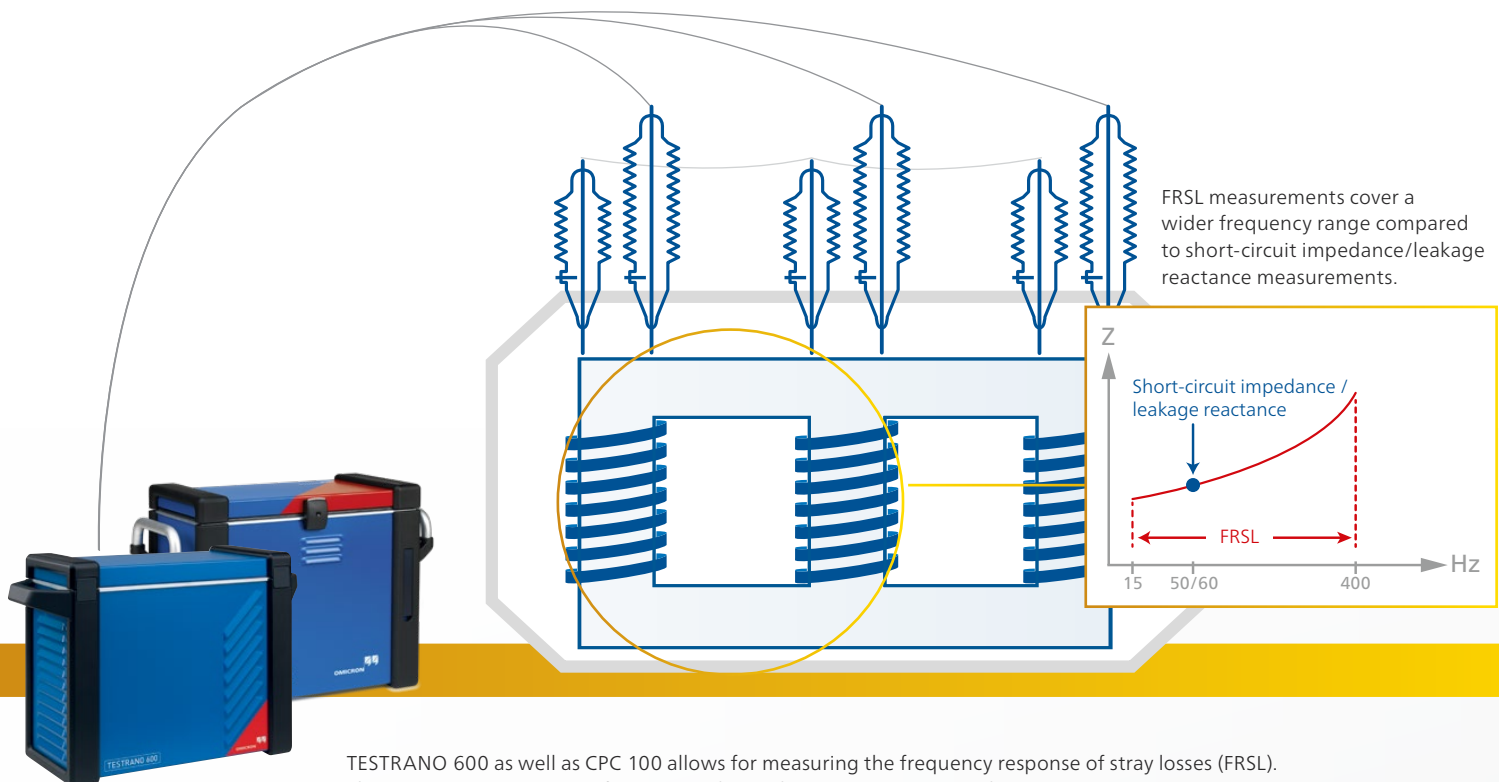

TESTRANO 600 as well as CPC 100 allows for measuring the frequency response of stray losses (FRSL). The TESTRANO 600 can perform a true three-phase measurement without any rewiring.

## Good to know ...

The analysis of FRSL results is largely visual and includes the comparison across phases and over time. Because the eddy losses are proportional to the frequency, an increase in impedance can be observed over the range of frequencies.

This increase should be uniform across all three phases, resulting in a smooth, exponential curve. Deviations as low as 3 %, especially in the higher frequencies, may already indicate a strand-to-strand short-circuit condition.

FRSL results should be cross-checked by performing dissolved gas analysis (DGA). Many of the problems which can be diagnosed using FRSL produce combustible gases.

For example, short-circuit strands may cause higher than normal overheating, which could be detected by DGA.

The most common problems which may result in misleading FRSL results are bad connections and small cross sections of the applied short-circuit jumper. In this case, a vertical offset between the phases can be observed.

### Why use TESTRANO 600?

- > True three-phase measurement to measure FRSL without reconnection
- > Same wiring used to test short-circuit impedance / leakage reactance tests

### Why use CPC 100?

- > Single-phase measurements to measure three-phase equivalent and per phase FRSL
- > Same wiring used to test short-circuit impedance / leakage reactance tests

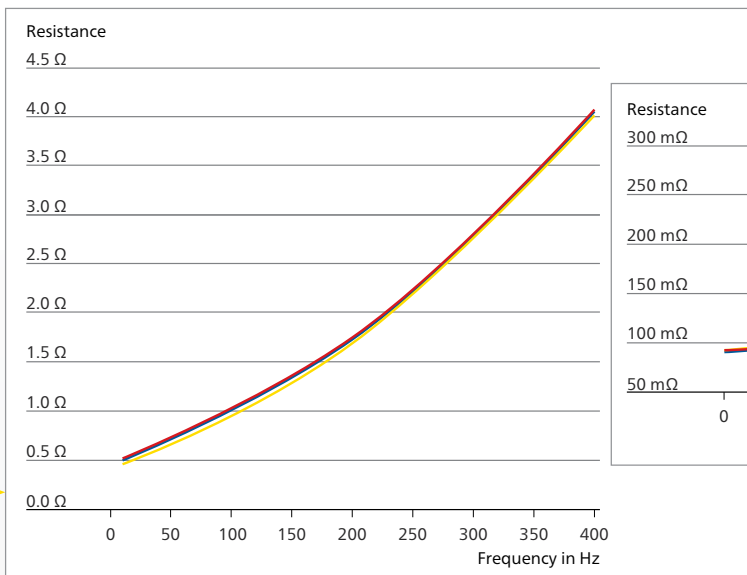

Acceptable FRSL results

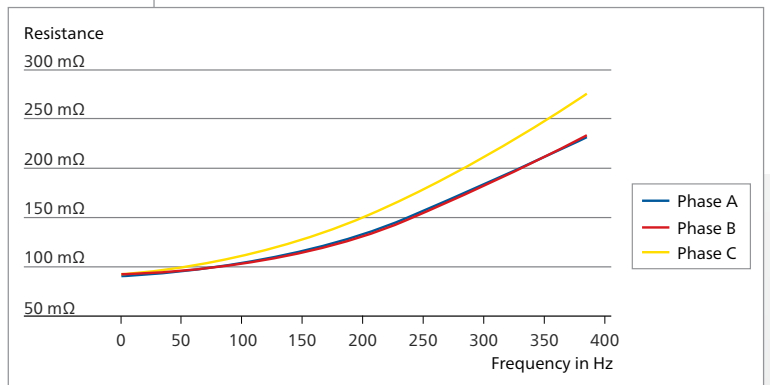

FRSL results indicate short-circuit in parallel strands in phase C winding

# Demagnetization

## What can be tested?

- Bushings
- CTs
- Leads
- Tap changer
- Insulation
- Windings
- ✓ Core

## Why measure?

Whenever a power transformer is isolated from the power system, residual magnetism remains in its core due to a phase shift. Residual magnetism also remains after a DC voltage has been applied to the transformer core, for example during routine winding resistance tests in the field or factory.

Due to residual magnetism in the core, high inrush currents, up to the maximum short-circuit current, can occur. This puts undesired stress on the transformer when it is switched back into service. In addition, many diagnostic measurements can be affected by residual magnetism, making a reliable assessment very difficult.

Therefore, it is recommended to demagnetize the core both before switching the transformer back into service and after DC voltages have been applied during diagnostic testing.

## How does it work?

First, the core is saturated in both directions then the specific hysteresis parameters are determined and the initial flux is calculated. Based on these parameters, an iterative algorithm is used to reduce the applied flux by adapting both voltage and frequency. Using multiple iterations, the core is demagnetized to below 1 % of its maximum value.

The described approach for demagnetization of a power transformer's core based on the measurement of the magnetic flux works reliably for both small and large power transformers.

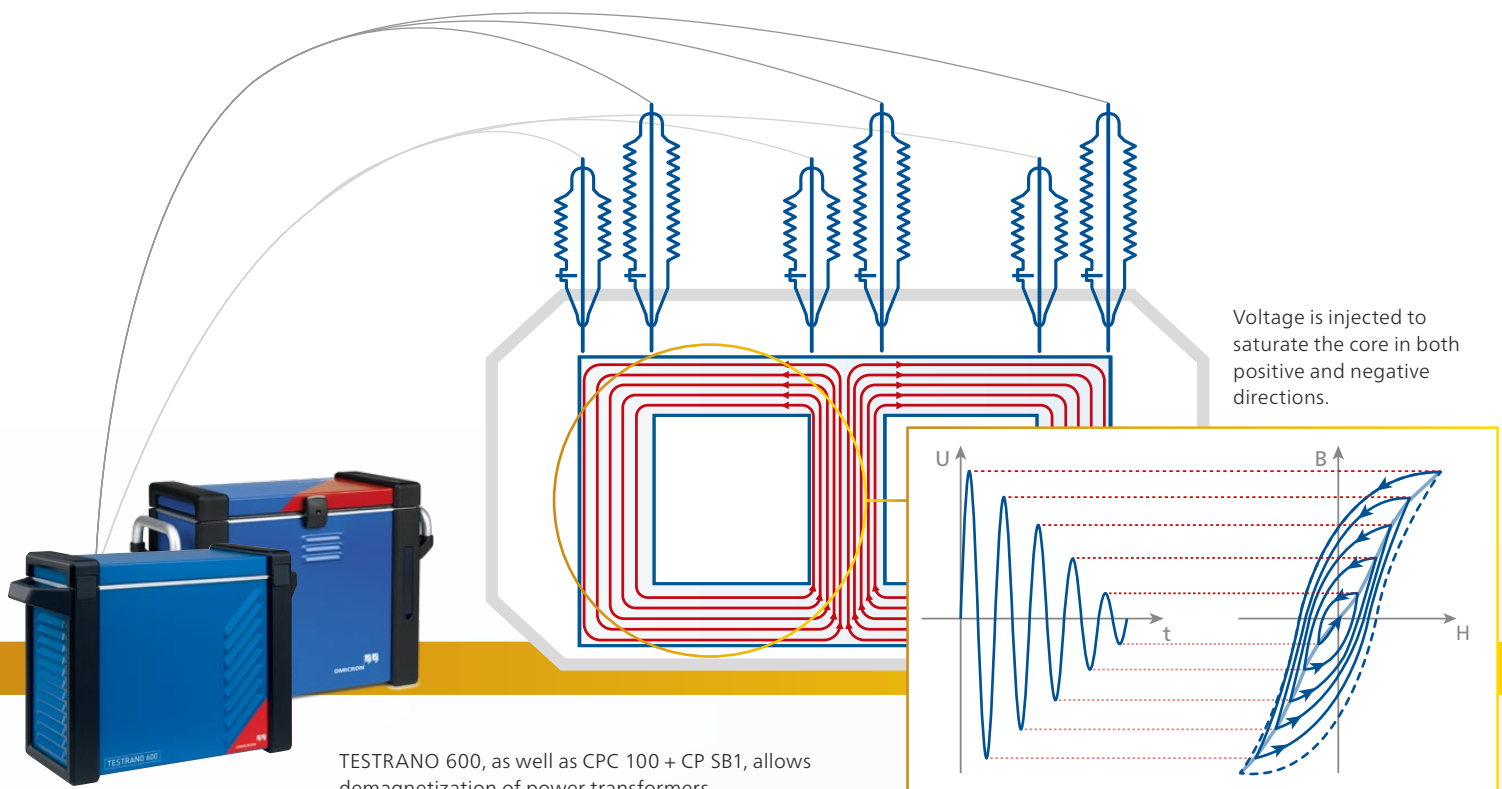

## Good to know ...

The demagnetization of the power transformer's core minimizes the risk for personnel and equipment when switching the transformer back into service.

It is also recommended to demagnetize the transformer before performing exciting current, sweep frequency response analysis (SFRA) or magnetic balance tests. All these measurements will be affected by a magnetized core which may lead to a false interpretation of the results.

An important aspect of a successful demagnetization is to constantly monitor the magnetic flux ( $\phi$ ) in the core during the demagnetization process.

## Why use TESTRANO 600 or CPC 100 + CP SB1?

- > Fast and reliable demagnetization of the power transformer core
- > Measurement of initial remanence for further diagnosis, e.g. of unexpected exciting current test results
- > Demagnetization to below 1 % of core's maximum value

High inrush current occurs due to residual magnetism and can jeopardize a transformer when it is switched back into service.

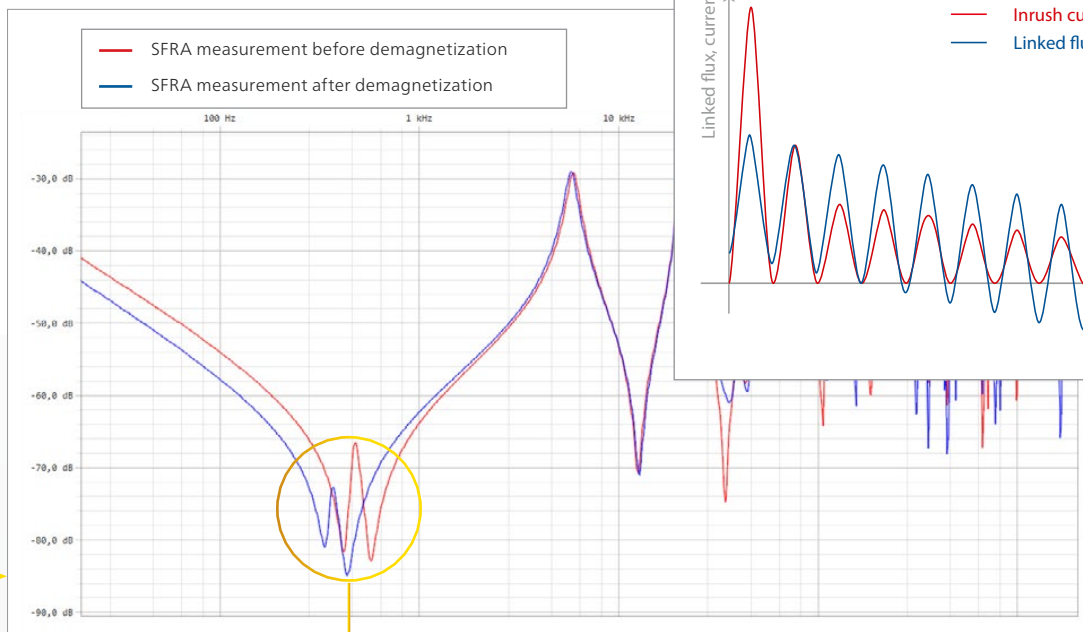

SFRA measurement on phase A: The shift in resonance points shows how the measurement is affected by the magnetized core.

# Sweep frequency response analysis (SFRA)

## What can be tested?

- Bushings
- CTs
- ✓ Leads
- Tap changer
- Insulation
- ✓ Windings
- ✓ Core

## Why measure?

Sweep frequency response analysis (SFRA) is used to identify mechanical or electrical problems in power transformer windings, contacts or cores. Severe short-circuits or shocks during the transformer's transportation may cause the winding to move or become deformed.

Since the IEC 60076-18 standard was introduced, this method has become one of the common electrical tests and its acceptance on the market has increased accordingly.

SFRA tests are recommended to be performed at the end of the acceptance test at the manufacturer's to establish the transformer's original fingerprint and then again after transportation, and during commissioning.

## How does it work?

Power transformers can be seen as a complex electrical network of capacitance, inductances and resistors. Each electrical network has its own unique frequency response.

A sinusoidal excitation voltage with a continuously increasing frequency is injected into one end of the transformer winding and the response signal returning from the other end is measured. The comparison of input and output signals generates a unique frequency response, which can be compared with the reference fingerprint.

Changes, movement or deformation of internal components lead to changes in this transfer function and can be identified by comparing the plots.

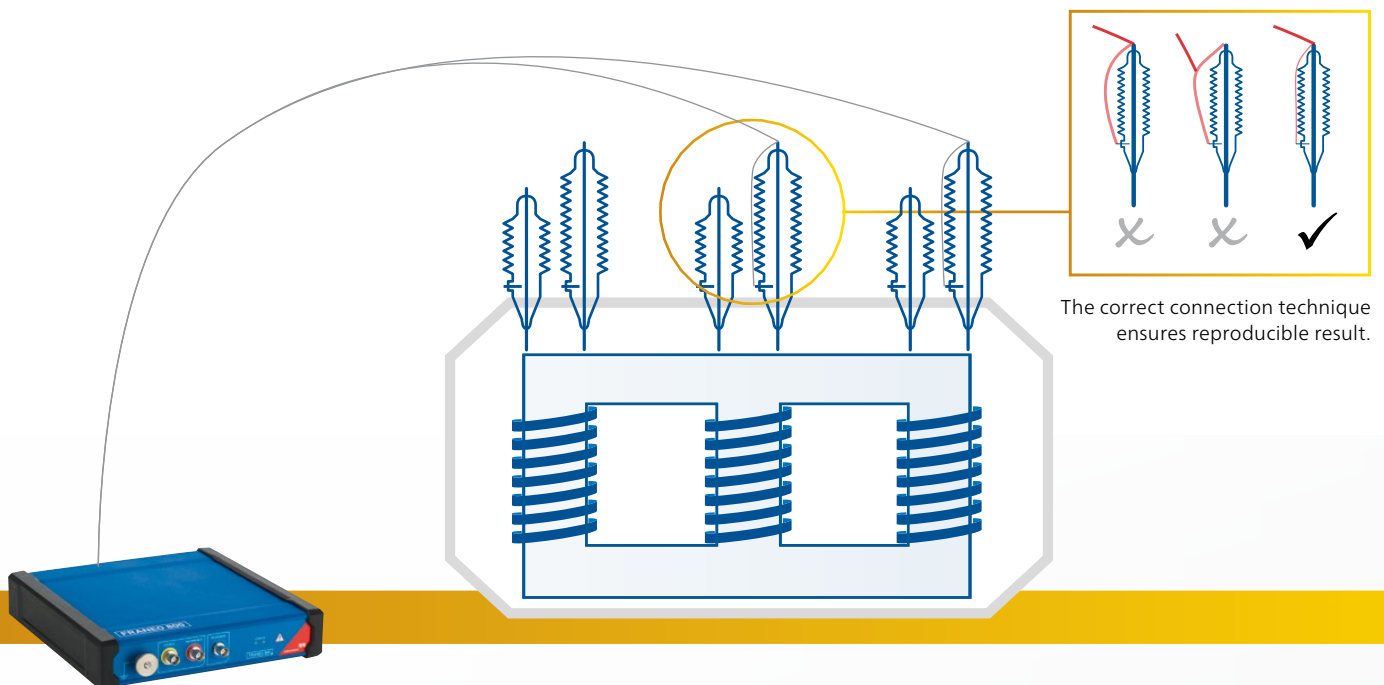

The correct connection technique ensures reproducible result.

FRNEO 800 allows reliable core and windings diagnosis of power transformers by using sweep frequency response analysis (SFRA).



## Good to know ...

SFRA is based on the comparison of a current test with a reference test. When such a fingerprint is not available, results of another phase or a similar transformer can also be used for comparison.

These detected faults can be confirmed by other measurements, such as DC winding resistance, frequency response of stray losses (FRSL), short-circuit impedance / leakage reactance, exciting current, or transformer turns ratio (TTR) measurement.

SFRA is a non-invasive method. It allows the reliable assessment of a power transformer's integrity without applying high-voltages.

No other method is as sensitive to mechanical deformations of the active part of power transformers as SFRA.

## Why use FRANEO 800?

- > Widest dynamic measuring range in the industry (> 150 dB)
- > Reproducible results thanks to innovative connection technique, based on IEC 60076-18, Method 1
- > Operating with Primary Test Manager™, thus guided workflow for test set-up, execution and assessment for easy analysis without expert knowledge
- > Fast measurement times due to intelligent sweep algorithms
- > Small and lightweight equipment guarantees optimum usability

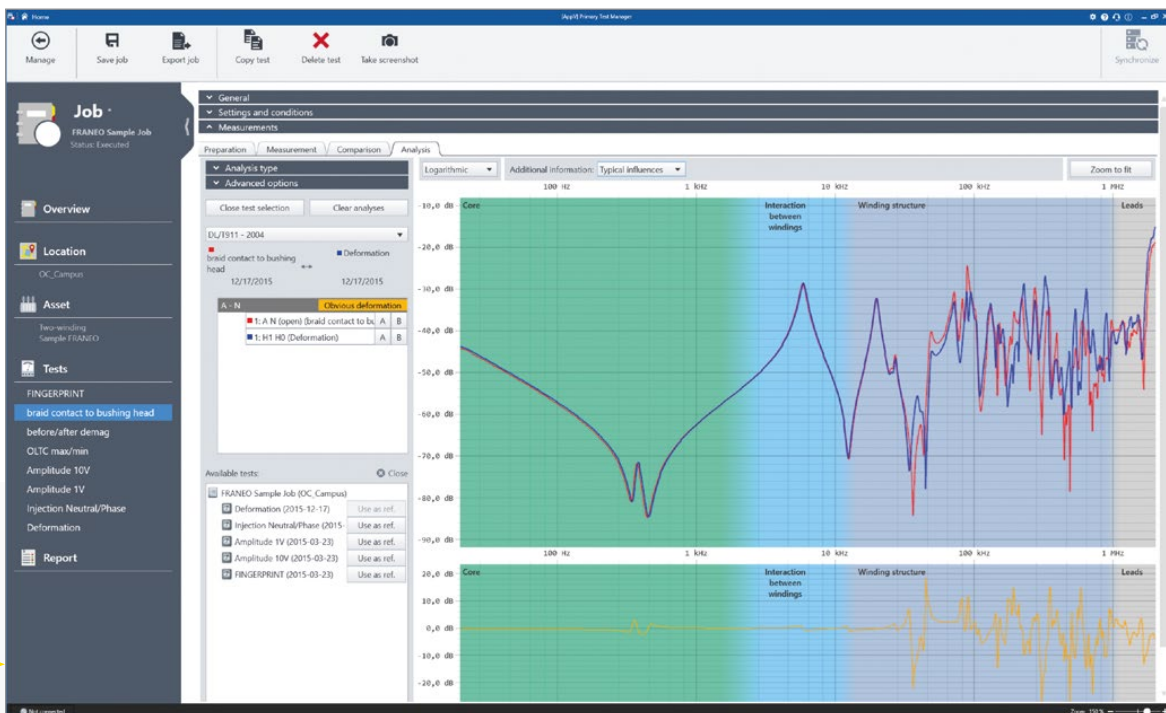

PTM offers automatic result assessment and comparison, also typical influences for deviations can be visualized.

# Dielectric (frequency) response analysis

## What can be tested?

- ✓ Bushings
- CTs
- Leads
- Tap changer
- ✓ Insulation
- Windings
- Core

## Why measure?

Dielectric response analysis, also known as dielectric frequency response analysis, is used to assess the moisture content of the cellulose insulation and, thus, determine its condition.

Moisture in oil-paper insulated power transformers is produced by paper aging or enters the transformer via leaky seals or breathing. It leads to a reduced breakdown strength and an increased aging of the insulation.

Knowing the moisture content is important for the condition assessment of the power transformer and its bushings. This measurement is also used for new transformers to prove the low moisture content after the drying process.

## How does it work?

The main amount of cellulose insulation in the active part of a power transformer is located between the primary and secondary winding. To measure this insulation, the output is connected to the high-voltage winding and the input to the low-voltage winding. Unwanted capacitive and resistive currents are bypassed by the guard connection which is applied to the tank.

The power factor/dissipation factor of this insulation is measured over a wide frequency range. The resulting curve contains information about the insulation condition.

The very low frequencies contain information on moisture in the solid insulation, while the position of the slope in the mid range frequencies indicates the conductivity of the liquid insulation. This curve is automatically compared to model curves and the moisture content of the cellulose insulation is calculated.

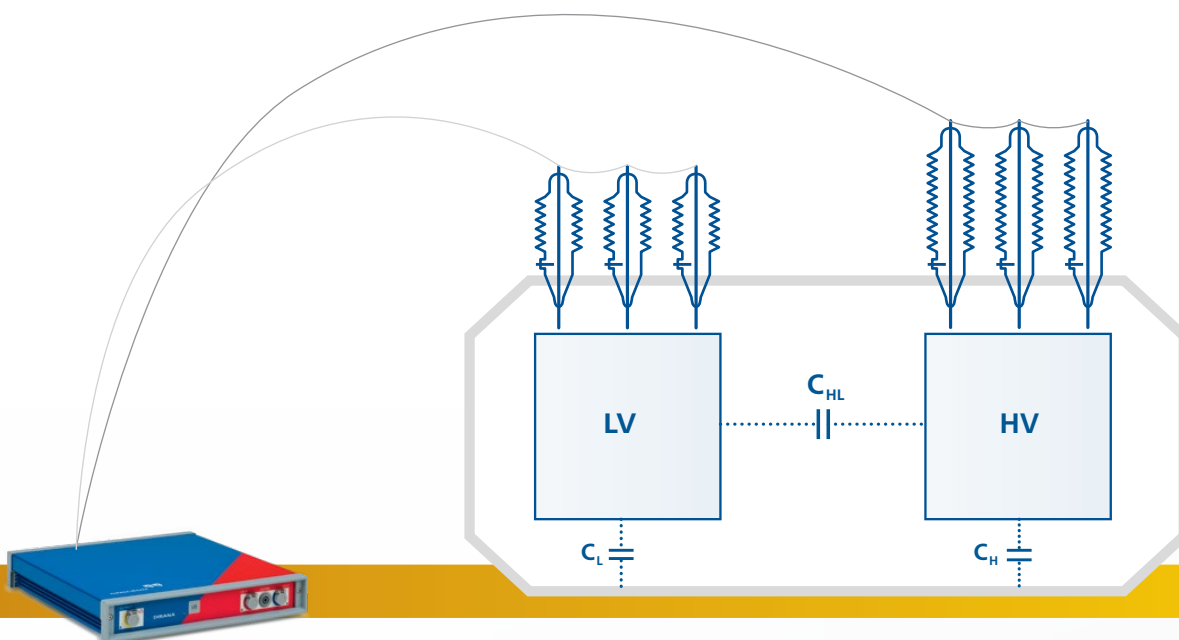

DIRANA determines the moisture content of oil-paper insulated power transformers and also assesses the condition of bushings by using dielectric response analysis.

## Good to know ...

This method is also scientifically approved by CIGRÉ. There are no other non-invasive ways to assess moisture in a transformer which provide comparable accuracy.

The moisture content is directly determined in the cellulose and not deduced from the moisture in the oil. Thus, the method is applicable at all temperatures and there is no need to wait until moisture equilibrium between paper and oil has been reached.

The assessment is performed according to IEC 60422 which provides categories for moisture levels.

## Why use DIRANA?

- > Reliable moisture determination of power transformers and oil-impregnated-paper (OIP) bushings.
- > Provides extremely short measurement times by combining measurement methods (FDS and PDC+)
- > Wide frequency range (10  $\mu$ Hz ... 5 kHz)

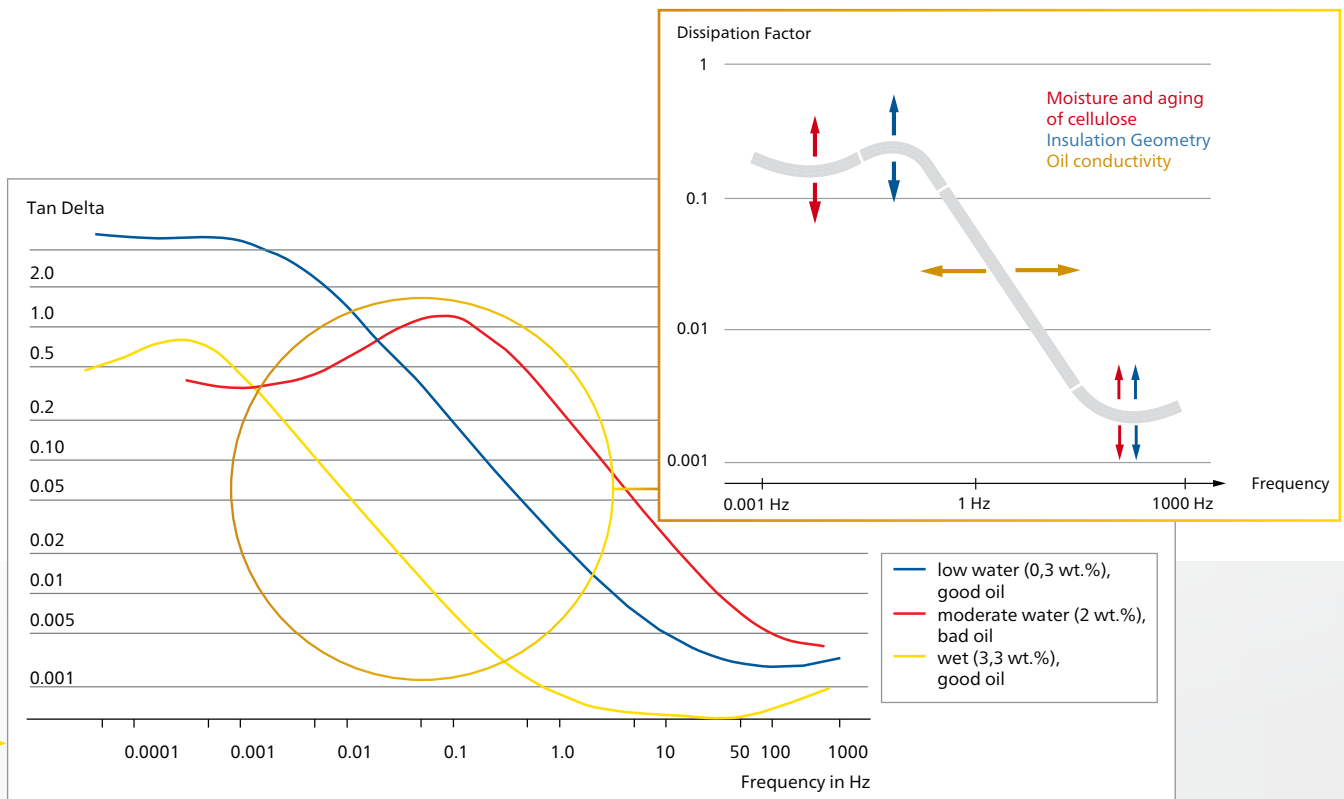

The dielectric response curve allows conclusions to be drawn about the different factors that influence the measurement result.

# Current transformer analysis

## What can be tested?

- Bushings
- ✓ CTs
- Leads
- Tap changer
- Insulation
- Windings
- Core

## Why measure?

The bushing current transformers (CTs) are tested by power transformer manufacturers during the final acceptance test, whereas substation operators test during commissioning. The tests check if the CTs send correct signals to the substation's protection system.

Wrong signals lead to maloperation of the protection system which may damage the connected assets. Checked parameters are the CT accuracy, including CT ratio error and phase displacement, accuracy for different burdens, CT winding resistance, CT excitation characteristics, ALF and FS.

All tests are performed in compliance with the standards: IEC 60044-6, IEC 60044-1, IEC 61869-2, IEEE C57.13

## How does it work?

Each phase is tested separately, the other phases must be short-circuited. A voltage is applied via the secondary side. This produces the magnetic force and the magnetic flux density in the CT core. The ratio error is calculated using the burden and the data of the CT model (equivalent circuit diagram), whose parameters are determined.

No high-current source is needed and the test must only be performed once, even when the CT must later be assessed using further burdens and primary currents. All relevant CT parameters are accurately measured, considering the CT's burden and excitation characteristics.

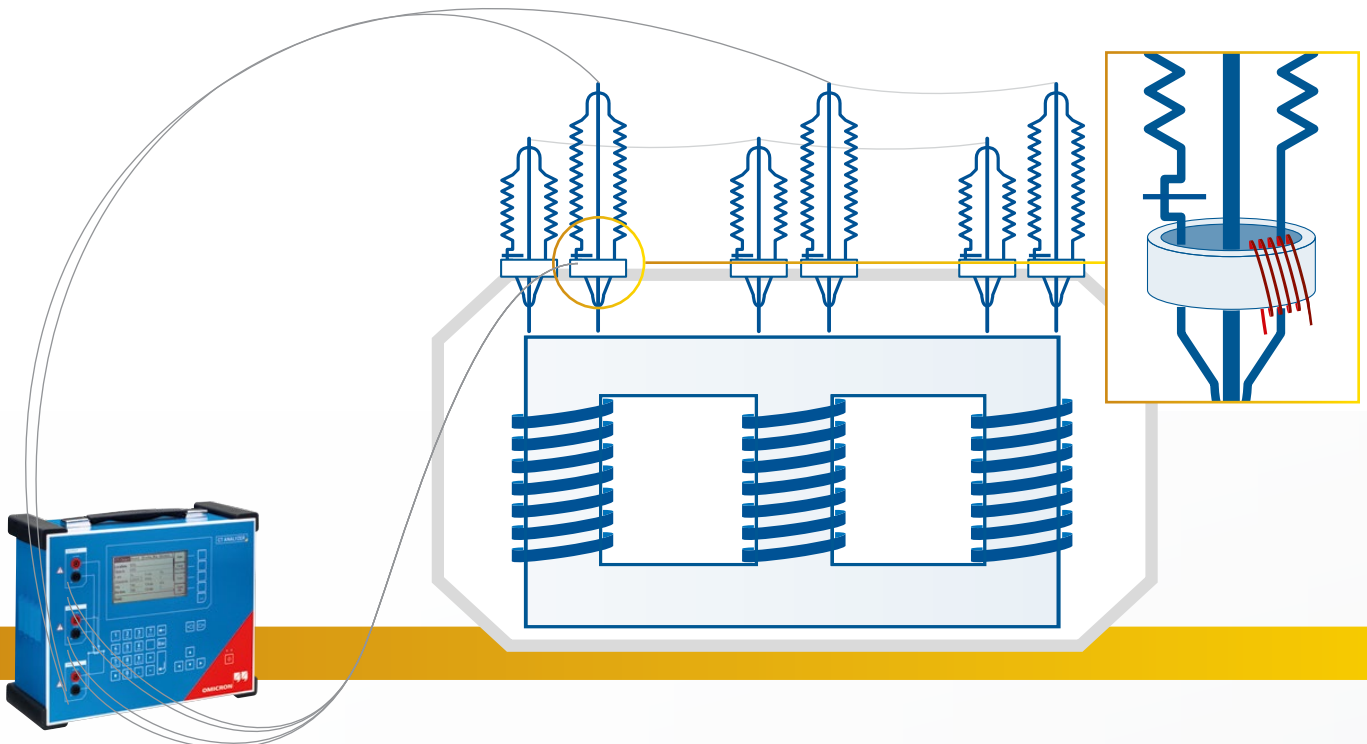

CT Analyzer performs diagnostic tests on bushing CTs.

## Good to know ...

The cycles and values for diagnostic tests on bushing current transformers (CTs) are defined in the respective standards and in the commissioning guidance of CT operators.

The CT error is determined for different connection methods of a transformer's windings. A polarity check verifies correct polarity of the CT and of the CT winding. The excitation curve is measured and the kneepoints are calculated. Remanence is measured and the CTs are demagnetized to avoid maloperation of the protection relay.

The larger the impedance of the burden, the smaller the margin until saturation is reached. Saturation of the core is reached when magnetization does not increase anymore while the external magnetic field strength is further increased. The result is a massive decrease of the CT efficiency and performance.

When measuring ratio of CTs mounted at the bushing of the transformer winding terminals, the voltage injection method is used instead of the current injection method due to the impedance of the transformer winding. For this method, a test voltage is applied to the secondary side of the CT and a voltage measurement is taken at the bushing terminals of the transformer windings. This test can also be performed using CPC 100 to check ratio, polarity and CTs protection class.

## Why use CT Analyzer?

- > Automatic demagnetization of CTs avoids maloperation of protection system
- > Automatic test report generation according to the standards
- > The secondary voltage injection method is the only way for testing bushing CTs already connected to power transformers
- > Extremely high accuracy (0.02 % typical) up to the 0.1 accuracy class
- > Compact and lightweight design (< 8 kg / 17.4 lbs)

CT-Objec...	Resistance	Excitation	Ratio
Secondary winding:			
I-DC:	0.962A	V-DC:	8.516V
R-meas:	8.852Ω	R-ref:	10.56Ω
T-meas:	25.0°C	T-ref:	75.0°C

CT-Object	Resistance	Excitation	Ratio
Nominal Burden	Current ratio error in % at % of rated current		
VA/Cosφ	100%	120%	
2.50/1.000	-0.009	-0.008	
1.25/1.000	-0.008	-0.007	
1.00/1.000	-0.007	-0.007	

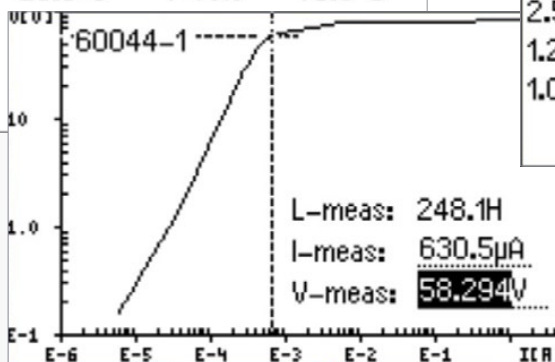

Resistan...	Excitati...	Ratio	Assessment
Standard: 60044-1	Class:	0.1	
Parameter	Auto	Manual	
Class	OK		?
ε	OK		?
Δφ	OK		?
FS	OK		?

Different test cards support you in checking and assessing relevant CT parameters such as ratio, resistance and its protection class.

# Partial discharge analysis

## What can be tested?

- ✓ Bushings
  - CTs
  - Leads
  - Tap changer
- ✓ Insulation
- ✓ Windings
  - Core

## Why measure?

Partial discharge (PD) can damage insulation materials in power transformer bushings and windings. This can lead to their failure and costly outages.

PD is observed in power transformer bushings and windings if the insulation material between different voltage potentials is aged, contaminated or faulty.

PD measurement is a reliable and non-destructive method used to diagnose the condition of a power transformer insulation system. It is performed during factory acceptance, on-site commissioning and routine maintenance testing to detect critical defects and assess risks.

## How does it work?

When measuring and analyzing PD activity in power transformers, the particular tests and test set-ups are determined by the type of transformer and to which standard the measurements are performed.

Depending on the type of bushings used, the PD analysis system is connected either to the capacitive tap of the bushings or to an external coupling capacitor. This allows electrical PD measurements on the transformer.

PD is measured either in  $\mu\text{V}$  (according to IEEE standards) or in pC (according to the IEC 60270 standard).

Advanced noise suppression techniques are commonly deployed in high-interference environments to minimize irrelevant data.

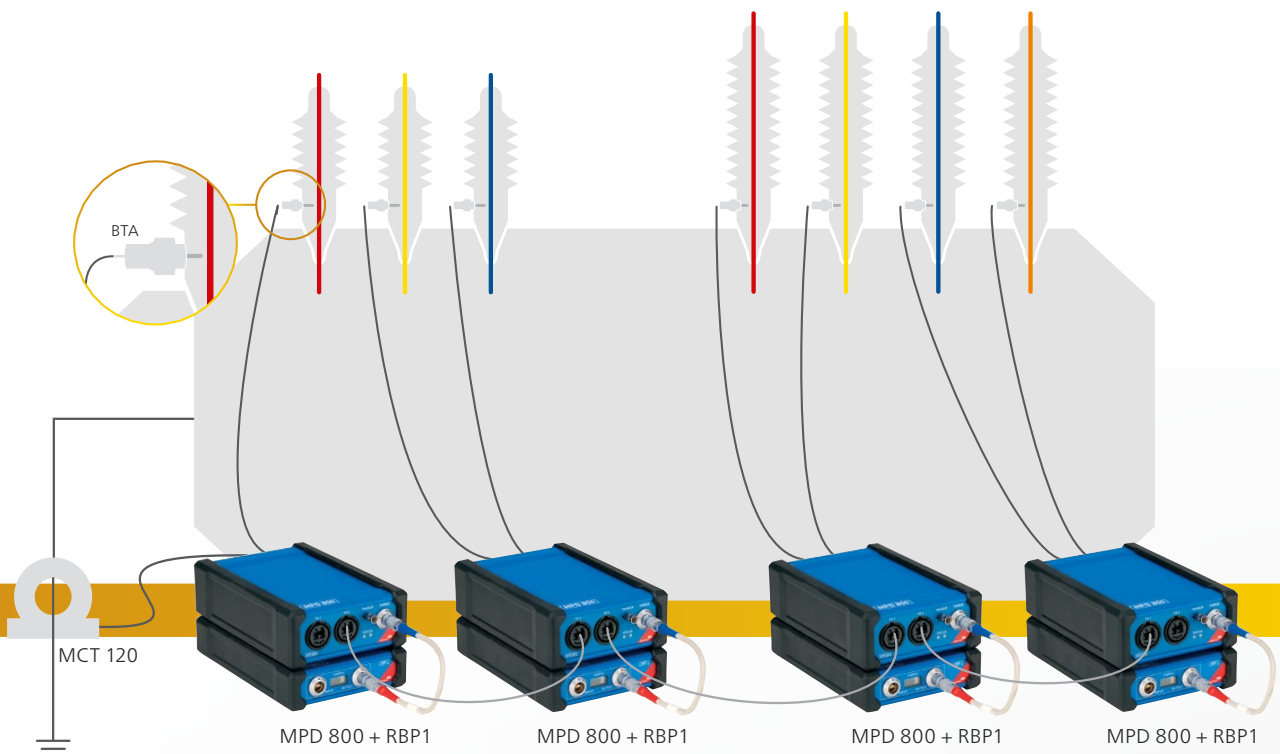

### Good to know ...

PD can also be directly measured inside the tank of liquid-insulated transformers using ultra-high frequency (UHF) sensors. UHF PD measurements can be used as an effective gating method to verify results – PD pulses from an electrical measurement at the bushings are only accepted if a UHF pulse from the transformer tank is also present.

Once PD activity is detected, acoustic PD measurements can be performed to accurately locate transformer defects.

For on-going risk management, an on-line dielectric condition monitoring system can be installed to continuously evaluate the insulation state of bushings and transformers.

### Why use MPD 800?

- > IEC standard-compliant PD measurements on power transformers
- > Galvanic isolation via fiber optic cables ensures safe operation
- > Synchronous, multi-channel PD measurement and gating capabilities
- > PD data set recording and playback for later analysis
- > Simultaneous PD ( $Q_{IEC}$ ) and Radio Interference Voltage (RIV) measurements for efficient factory acceptance testing
- > Advanced noise suppression and source separation techniques for reliable PD analysis
- > Customizable software allows users to select only the PD analysis tools they need

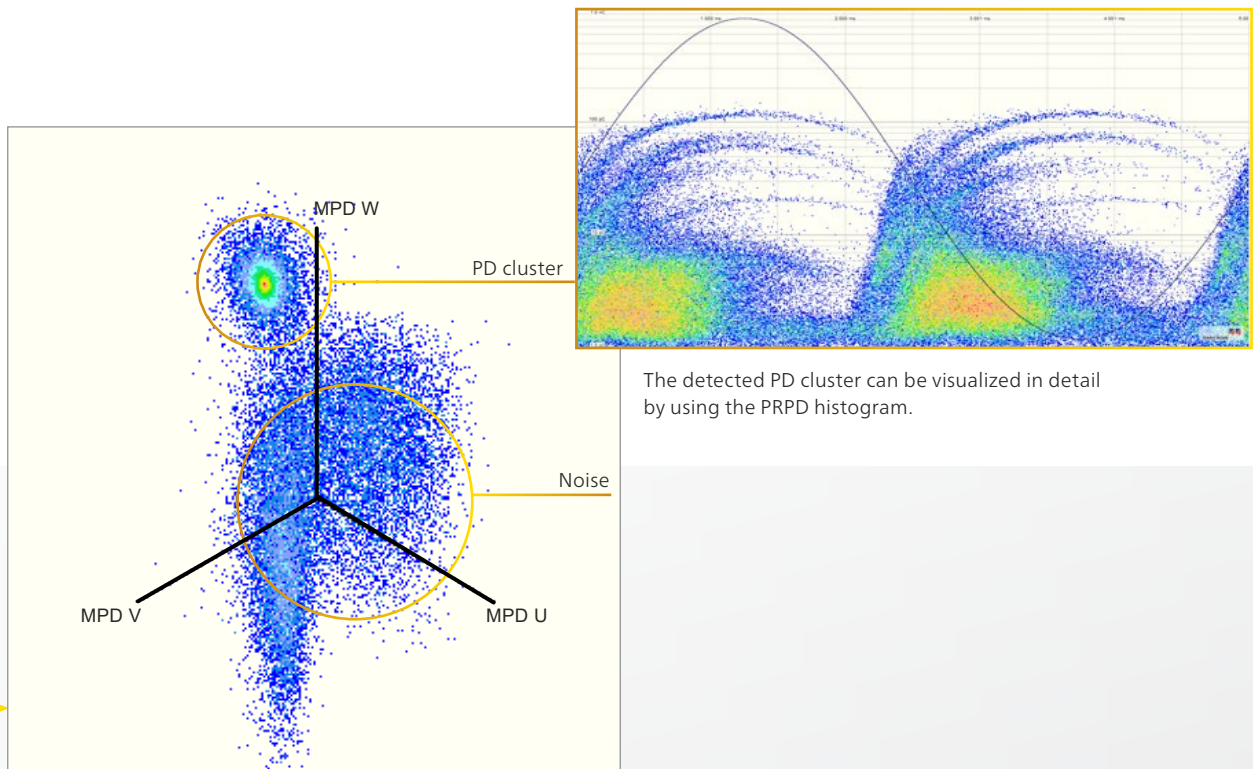

The detected PD cluster can be visualized in detail by using the PRPD histogram.

A 3PARD (3-Phase Amplitude Relation Diagram) separates PD sources from noise

# Partial discharge localization

## What can be tested?

- Bushings
- CTs
- Leads
- Tap changer
- ✓ Insulation
- ✓ Windings
- Core

## Why measure?

Partial discharge (PD) can cause irreversible damage to power transformer insulation, long before the insulation actually fails. Even upon detection and analysis, it is essential to know exactly where insulation defects are located in the transformer.

Through acoustic PD measurements, weak points or defects in the insulation can be precisely located. Once the exact defect location is known, remedial steps can be efficiently planned and executed to prevent failure.

Acoustic PD measurements are conducted after PD has been detected during factory acceptance tests, and are an integral part of on-site diagnosis measurements during the service life of power transformers.

## How does it work?

Multiple acoustic sensors are magnetically mounted to the surface of a power transformer tank. Each sensor measures the acoustic signal propagation time from the PD source to the tank wall. Defect location is then calculated based on time differences, sensor position and propagation speed.

The data gathered by these sensors is compared simultaneously to accurately identify the defect location.

The IEEE C57.127-2007 standard describes the typical workflow of an acoustic measurement.

PDL 650 setup at a power transformer with four acoustic sensors.

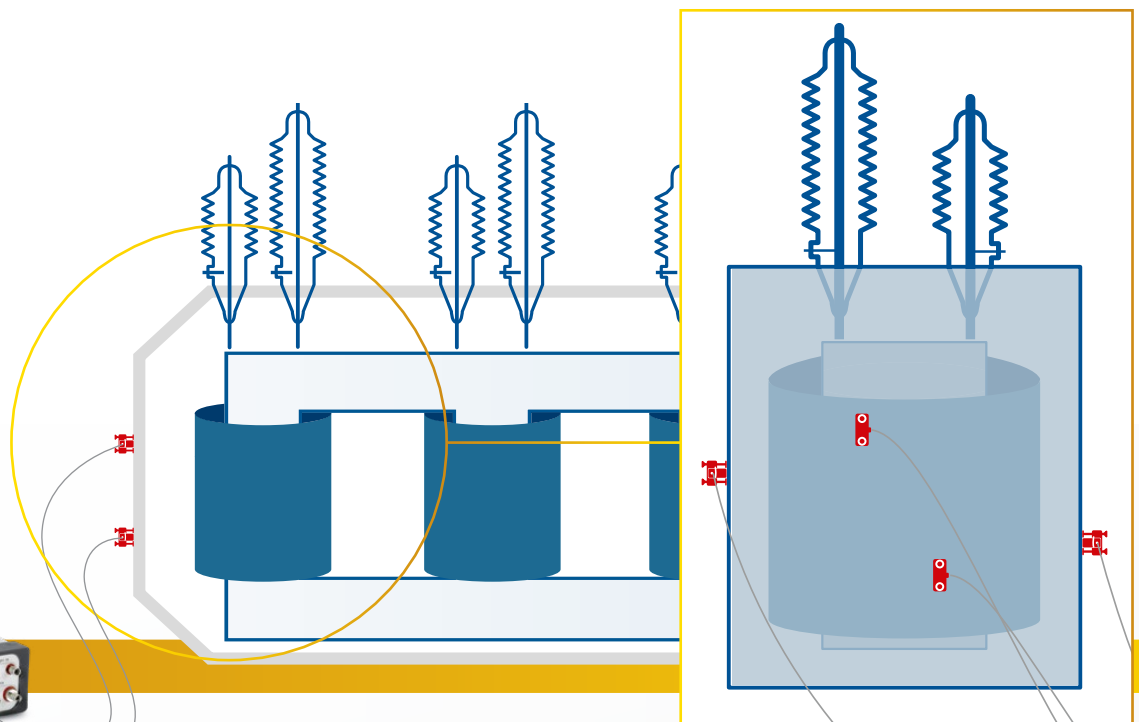

Multiple acoustic sensors spread over the transformer wall help to locate the defect.



## Good to know ...

Dissolved gas analysis (DGA) can indicate PD activity, but it cannot actually localize it in power transformers. Acoustic PD measurements are therefore performed if DGA results show evidence of PD.

The combination of electrical and ultra-high frequency (UHF) PD detection measurements can be used to trigger an acoustic PD measurement. This method ensures optimal PD localization in environments with heavy interference.

Acoustic PD measurements are performed while power transformers are online. This eliminates the need for an outage to keep the transformer in full service.

## Why use PDL 650?

- > Modular, lightweight design for easy transportability and on-site setup
- > Safe due to galvanic separation of operator from high-voltage
- > 3D visualization enables users to clearly see defect locations inside the transformer
- > Electrical triggering in combination with the MPD 600 and UHF sensors ensures optimal PD localization in noisy environments

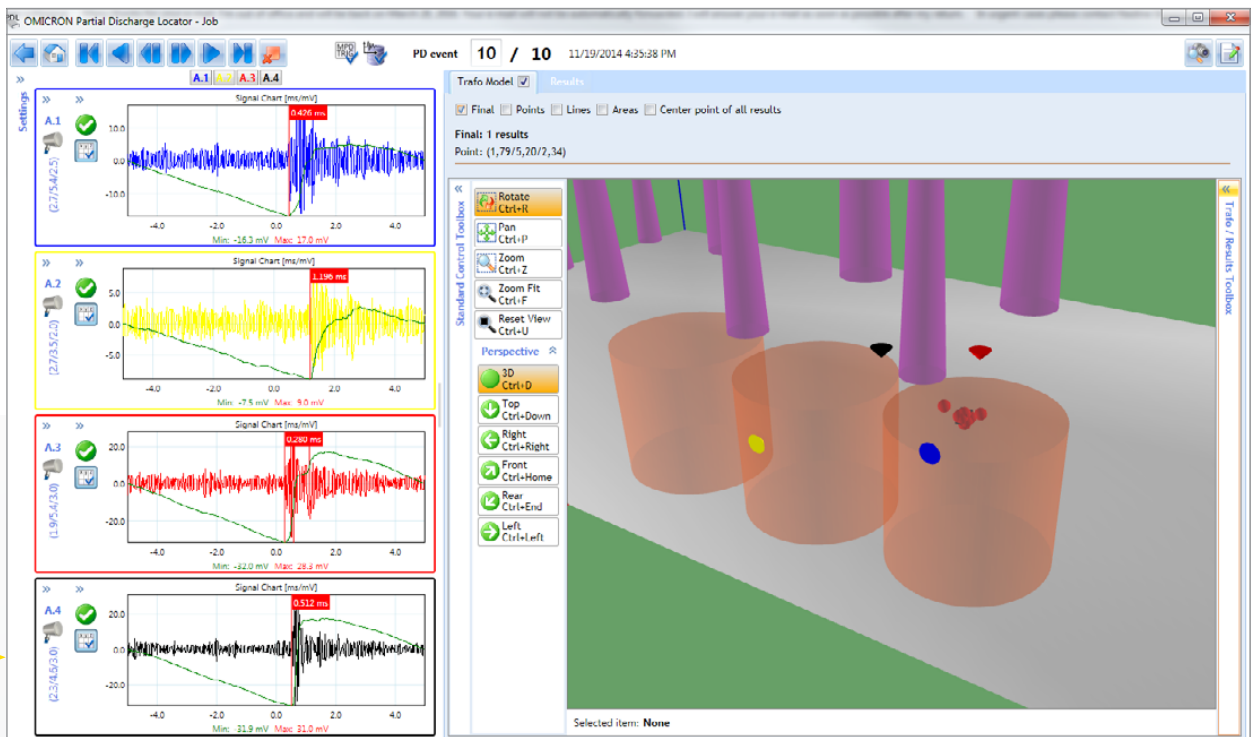

3D model of the transformer reveals the exact PD location.

# On-line partial discharge measurement & temporary monitoring

## What can be tested?

- ✓ Bushings
  - CTs
  - Leads
  - Tap changer
- ✓ Insulation
- ✓ Windings
  - Core

## Why measure?

Partial discharge (PD) can damage insulation materials in power transformer bushings and windings. This can lead to insulation breakdown and costly outages. PD is observed in power transformer bushings and windings if the insulation material between different voltage potentials is aged, contaminated or faulty.

On-line PD measurement evaluates PD activity and offers a snapshot of insulation condition status when the power transformer is in operation. Temporary on-line PD monitoring indicates changes in PD activity over specified periods of time during the power transformer's service life.

The data gathered during on-line PD measurement and monitoring enables engineers to determine when electrical equipment is at risk of failure. This vital condition-based information helps to optimize maintenance strategies, asset management and investment planning.

## How does it work?

The combined on-line PD measurement and temporary monitoring system can be easily connected to permanently-installed bushing tap sensors via a terminal box. This enables a safe and convenient plug-and-play set up when power transformers are on line. The operator can perform a PD measurement whenever it is needed, even during normal operating conditions without shutting down the transformer.

PD activity is synchronously measured on all three phases at the bushing taps and inside the transformer tank in the UHF range. Advanced diagnostic tools, such as 3PARD (three-phase amplitude relation diagram), are used to separate noise and multiple PD sources for reliable interpretation.

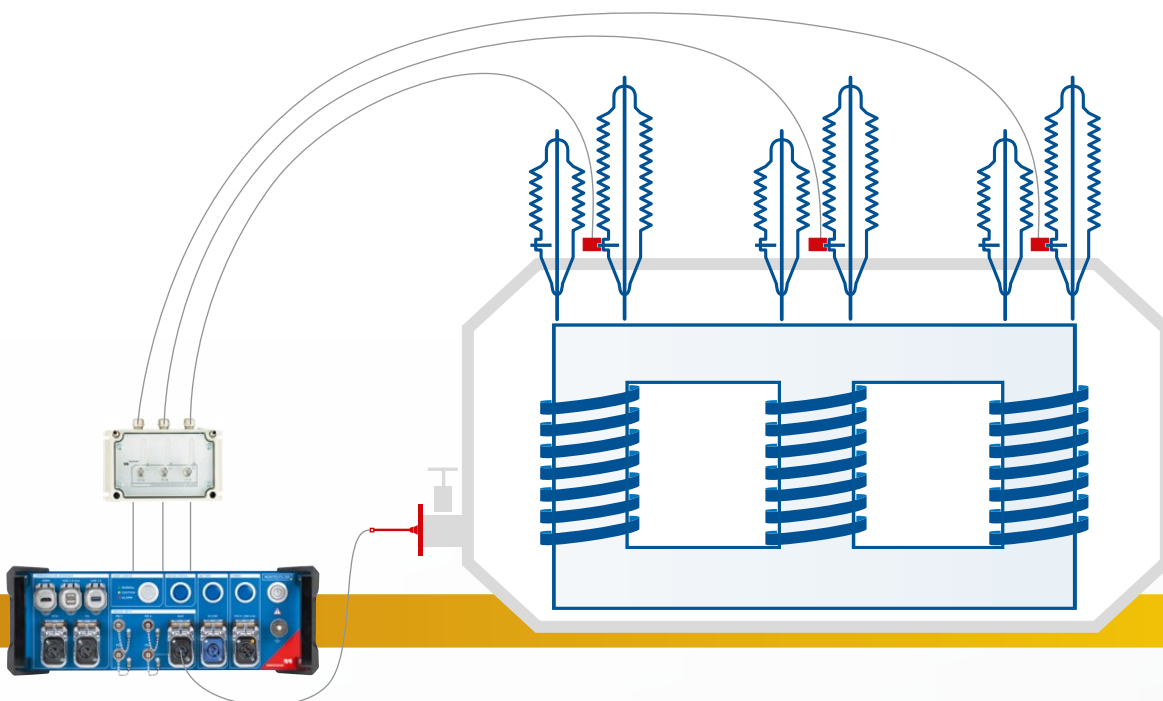

The MONTESTO 200 PD measurement and temporary monitoring system can be easily connected to permanently-installed bushing tap sensors via a terminal box. This enables a safe and convenient plug-and-play set up when power transformers are on line.

## Good to know ...

On-going PD activity in the bushings and windings is best confirmed by monitoring PD at the bushing taps and in the UHF range.

Periodic oil sampling and lab dissolved gas analysis (DGA) can be triggered to confirm dielectric trends by detecting the by-products of insulation degradation dissolved in the transformer oil.

Acoustic PD measurements can be deployed after PD has been detected for accurate and reliable localization of insulation faults in transformer windings.

## Why use MONTESTO 200?

- > 2-in-1 solution for on-line PD measurement and temporary monitoring
- > Compact and lightweight for easy transport
- > Designed for indoor and outdoor use
- > Built-in computer for continuous, long-term data collection and archival
- > Web-based interface for convenient remote data access
- > Automated software features for easy PD data analysis and reporting

Event Log - TRAF0 UM6		
Confirm All		
Start Date ▼	End Date	Level ▼
8/22/2018 3:14 PM	8/22/2018 3:15 PM	Critical
8/22/2018 3:14 PM	8/22/2018 3:15 PM	Warning
8/22/2018 3:14 PM	8/22/2018 3:15 PM	Warning

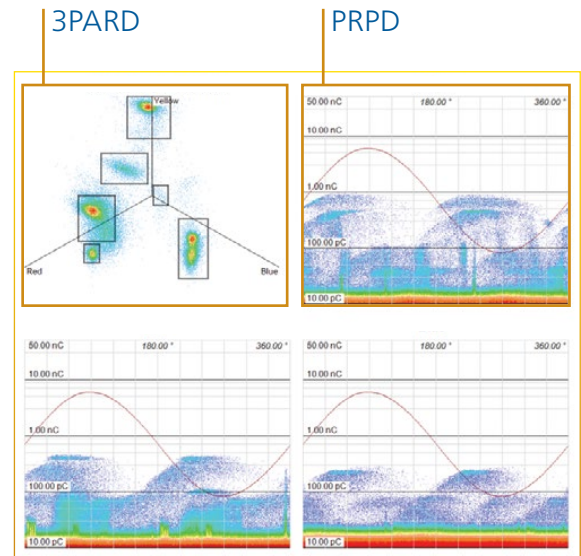

The event log shows which PD events triggered a warning (yellow) or alarm (red).

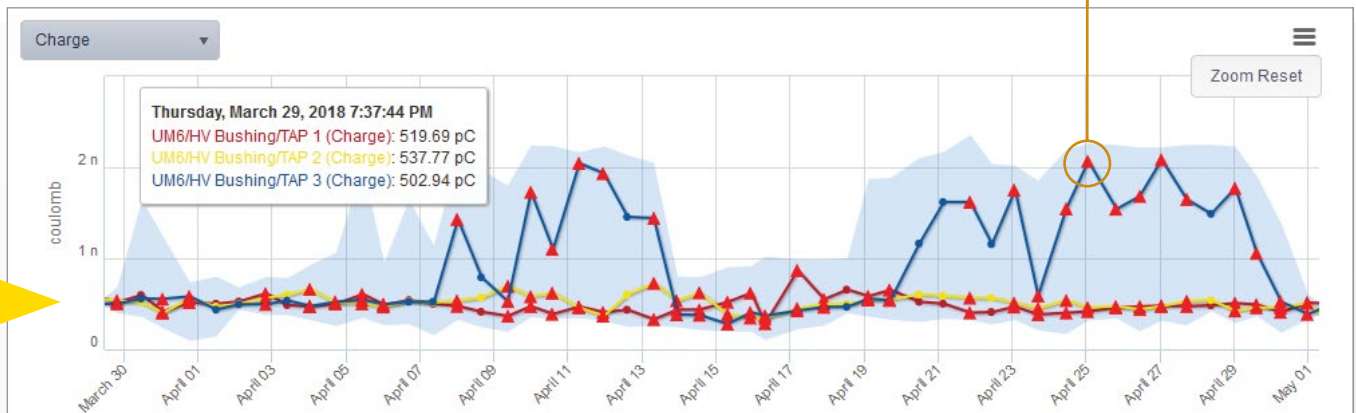

PD trend charts for each phase or channel. Scrolling over points displays PD values. Users can zoom in to see more detail.

# A strong and safe connection

## Welcome to the team

At OMICRON you can always depend on an experienced team that actively supports you and an infrastructure that you can rely on. We always listen attentively in order to understand your needs so that we can offer you the best possible solutions. We strive for lasting partnerships and ensure that you can continue to rely on your product long after you've purchased it. In order to do this, we focus on quality, the transfer of knowledge and unique customer support.

Charles, Wenyu and René are able to tell you about the services we have available for you and why it pays to be part of the team.



Charles Sweetser  
Application Specialist

## Solutions you can rely on...

... developed with experience, passion and an innovative approach that we use to continually set groundbreaking standards in our industry sector.

We invest more than 15 % of the total turnover in research and development so that we can even guarantee the reliable use of the latest technology and methods in the future.

Our comprehensive product care concept also guarantees that your investment in our solutions – like free software updates – pays off in the long term.





Wenyu Guo  
OMICRON Academy



### We share our knowledge...

... by maintaining a constant dialogue with users and experts. Some examples of this are our customer events and conferences that take place all over the world and our collaboration with numerous standardization committees.

We also make our knowledge available to you in the customer section of our website in the form of application reports, specialized articles and articles in the discussion forum. With the OMICRON Academy, we also provide a wide spectrum of training possibilities and assist you with Start-up training and free webinars.



René Ulmer  
Technical Support

### 24/7 support

#### When rapid assistance is required...

... our excellent level of support is always appreciated. You can reach the highly-qualified and committed technicians in our customer support department 24 hours a day, seven days a week – and it's completely free. We deal with repair services and service features in a fair and non-bureaucratic manner.

We can help minimize your downtime by lending you equipment from a readily available plant at one of our service centers in your area. A comprehensive offer of services for consulting, testing and diagnostics completes our range of services.

# OMICRON – Who we are

## Reliable. Passionate. Different.

For over 30 years we have been developing innovative, top-quality testing and monitoring solutions for electrical power systems.

Customers in more than 160 countries rely on OMICRON's testing technology. In addition, we offer a wide array of services in the fields of consulting, testing and training.

We aim to inspire our customers with exceptional products, an interactive exchange of knowledge and extraordinary customer support. Our curiosity and passion give us the courage to approach things from different angles.

Together with our partners and customers, we are striving towards a safe and reliable energy supply.

*„Create an environment with no artificial limits where a team of excellent members can reach an excellent performance and enjoy working together at the same time.“*

(Rainer Aberer, company founder)

## Our values

We acknowledge our social, ecological and corporate responsibility, and are committed to ensuring sustainable development and business practices. The majority of development and production work takes place at our premises in Austria. Highly specialized suppliers from the region and first-class components guarantee the reliability and durability of every OMICRON device.

Over 900 employees from 45 different countries shape our extremely diverse corporate culture today. Flat hierarchies and a high degree of individual responsibility create a motivational work environment in which our employees can realize their full potential. Actively practiced corporate values such as respect and trust lead to our unique company spirit.

Founding of  
OMICRON in Austria

1984

Entering the fields of protection  
and measurement technology

1990

First major OMICRON  
protection testing conference

1993

OMICRON has  
over 100 employees

2000

Entering the field of  
primary equipment  
testing

2001





The world of OMICRON

OMICRON is an international company that develops, manufactures and markets transformer systems for the electrical energy of primary and secondary substations including auxiliary power supply systems and power transformers.

By combining innovation, local application knowledge and international customer support, OMICRON is a leader in its sector.

With more than 20 countries offices in Europe, Africa, Asia and North America, and a continuous presence of products and representation, OMICRON has truly established a reputation of the highest quality.

Customers in over 100 countries worldwide



Entering the field of online monitoring

Over 900 employees in more than 20 offices worldwide



2003

2009

2019

OMICRON is an international company serving the electrical power industry with innovative testing and diagnostic solutions. The application of OMICRON products allows users to assess the condition of the primary and secondary equipment on their systems with complete confidence. Services offered in the area of consulting, commissioning, testing, diagnosis and training make the product range complete.

Customers in more than 160 countries rely on the company's ability to supply leading-edge technology of excellent quality. Service centers on all continents provide a broad base of knowledge and extraordinary customer support. All of this together with our strong network of sales partners is what has made our company a market leader in the electrical power industry.

For more information, additional literature, and detailed contact information of our worldwide offices please visit our website.