

Anritsu envision:ensure

Network Master Pro CPRI RF Module

The perfect tool for troubleshooting interference at ground level



CPRI RF Measurements

The MT1000A Network Master Pro is a handheld battery power tester designed to facilitate the installation and maintenance of cellular networks. CPRI RF measurements are configured and displayed on the 9 inch color touch screen.

Flexible Form Factor

The MU100040A CPRI RF Module for the MT1000A Network Master Pro adds CPRI RF measurements to Anritsu's transport and fiber test platform. The modular design of MT1000A means that it can be configured just for CPRI RF measurements or combined with the 10G transport module and OTDR module to create the most comprehensive and versatile fiber and transport tester available.

Key Features

- Displays LTE spectrum of ALU/Nokia, Ericsson and Huawei CPRI radios
- Eliminates need to climb tower to fault find Remote Radio Heads (RRH)
- Fast update rate to capture intermittent interferers
- Spectrum pan and zoom for detailed analysis of interferers
- Spectrogram display captures and holds data for intermittent interferers
- 2 SFP slots
- SFP data reading and display
- Layer 2 alarm monitoring and display
- Auto configuration of CPRI parameters
- Modular design for use with MT1000A OTDR and 10G transport test modules
- Battery powered for field use

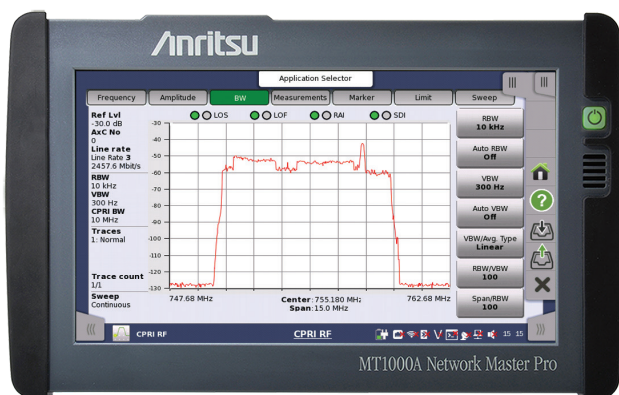

Network Master™ Series MT1000A/MU100040A

Network Master Pro CPRI RF Module

The MT1000A is the world's first instrument to combine all of the tools that field engineers and technicians require to maintain fronthaul and CPRI based Remote Radio Heads (RRH). The modular design offers the ability to add options 10 Gb Ethernet, OTDR, Visual Inspection Probes and CPRI RF measurements in a single platform. This leads to reduced capital expenditure and increased operational efficiency.

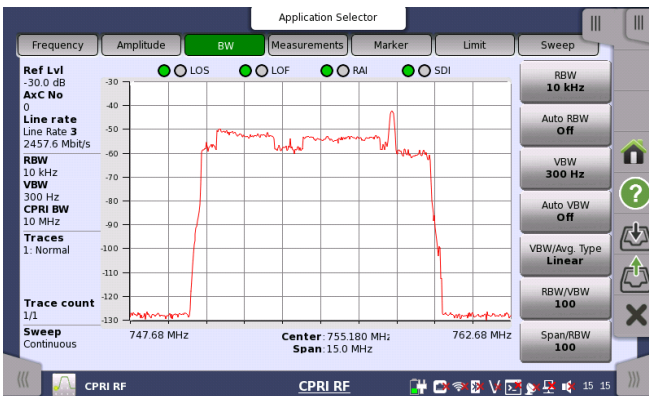

View the live spectrum of an LTE uplink. The fast update rate shows resource blocks being activated dynamically as well as enhancing ability to see intermittent interferers. Layer 2 alarms are displayed by indicator lamps at the top of the screen to confirm the integrity of the signal. An interfering signal is clearly visible in the LTE spectrum.

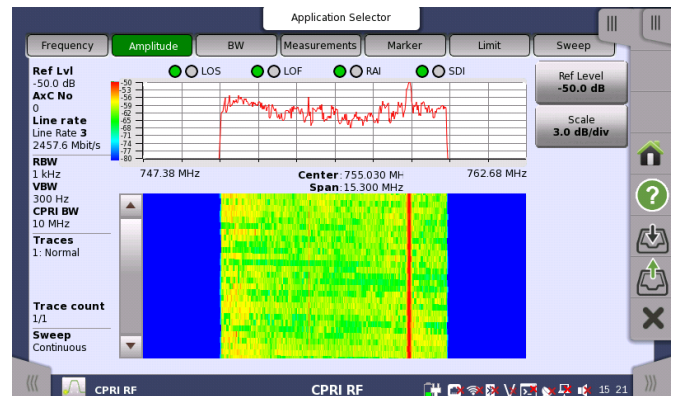

A spectrogram feature is ideal for long term monitoring of the spectrum. The spectrogram provides a timed history of all captured spectrums, so intermittent interferers are not lost.

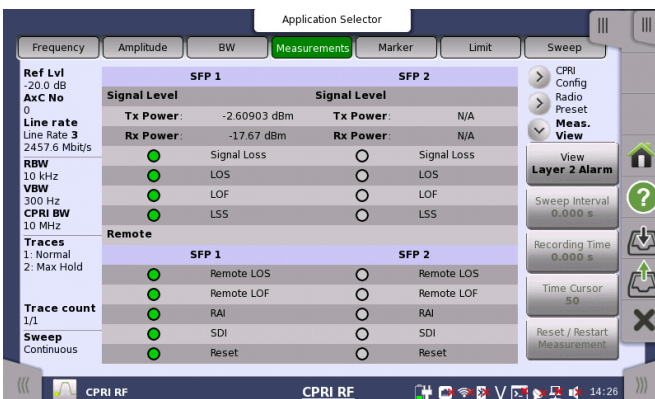

The Layer 2 alarm screen shows full details and status of both SFP ports.

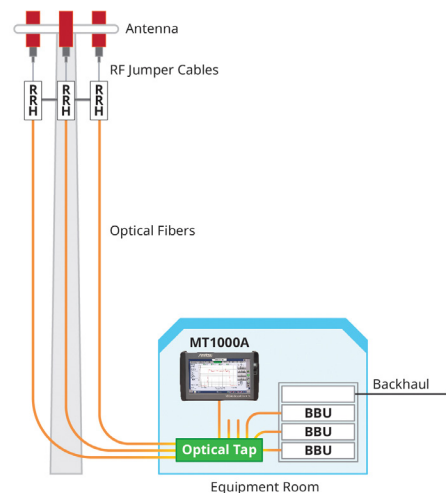

The MU1000040A CPRI RF module monitoring at ground level.

For more details visit: www.anritsu.com

